

CVI B4

Module with 4 analog inputs and 10V external reference

Datasheet

Description

Module with 4 digital analog inputs. Main characteristics:

- 4 analog inputs 0-10 V or 0-20 mA
- 1 voltage reference 10V
- 12 bit resolution
- Status and diagnostic LEDs

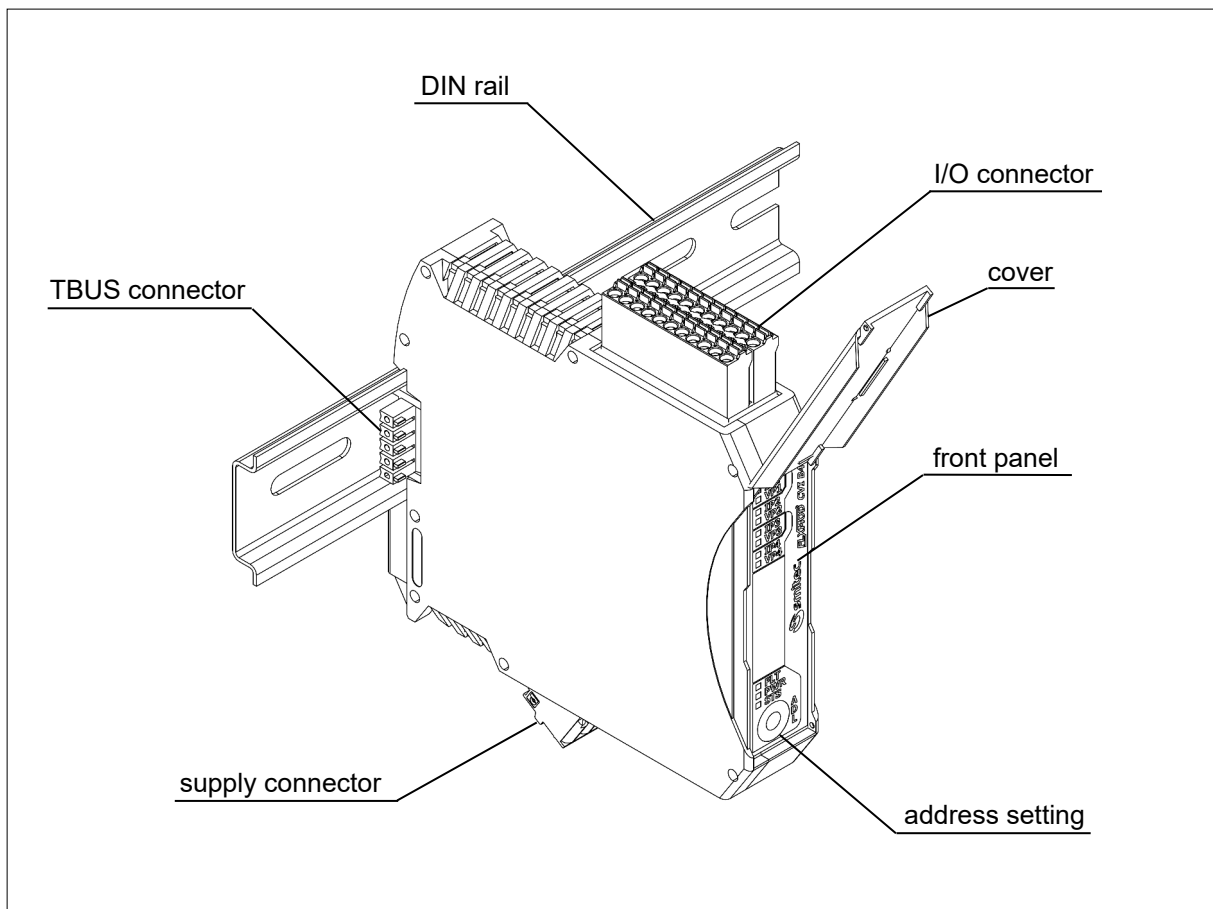

Ordering information

Products	SMITEC part number
Module with 4 analog inputs, complete with accessories (power connector, inputs connector and TBUS connector)	KZ010362

Accessories	SMITEC part number
Power supply connector (Phoenix Contact p/n 1910377)	KF100009
I/O connector (Phoenix Contact p/n 1738898)	KF101048
TBUS connector (Phoenix Contact p/n 2713722)	KF101034
Power supply fuse (Littelfuse p/n 0452 002)	KD201035

Documentation	SMITEC part number
Installing instructions	DK400042
Datasheet for CVI B4	DK400147
FLXIO and FLXMOD system integration manual	DK400076

Technical data

General data	
Housing dimensions (width x height x depth)	22.5 mm x 99.0 mm x 114.5 mm
Weight	103 g (without connectors), 125 g (with connectors)
Connection method for connectors	Spring cage terminals
Conductor cross-section (power connector)	0.2 to 2.5 mm ² (24 – 12 AWG)
Conductor cross-section (output connector)	0.2 to 1.5 mm ² (24 – 16 AWG)
Functional earth connection	To the DIN rail by spring contact
Mode state visual indicators	Fault (FLT) and status (STS) LED lamps

Environment data	
Permissible operating temperature	+5° to +55°C
Permissible storage and transport temperature	-25° to +85°C
Permissible humidity	10% to 95%, not condensing
Permissible air pressure (operation)	80 to 106 kPa (up to 2000 m above sea level)
Permissible air pressure (storage and transport)	70 to 106 kPa (up to 3000 m above sea level)
Degree of protection (CE)	IP20 according to IEC 60529
Degree of protection (UL)	Open Type
Overvoltage category	II
Pollution degree	2
Means of protection (UL)	Class III SELV power supply

Power supply	
Main power supply V_m	24 V DC \approx (-15% ÷ + 20% according to IEC 61131-2)
Maximum allowed ripple	5% of supply voltage (according to IEC 61131-2)
Current consumption from main supply	1.5 A max. (for external loads supply)
Supply overvoltage protection	Bidirectional Zener clamp ($V_z > 30$ V)
Supply reverse polarity protection	Protection diode and safety fuse
Supply fuse	2 A, not replaceable by the user
Local bus power supply	5 V DC (from local bus)
Local bus supply protections	None
Power presence visual indicators	Green LED lamp, lighted if main supply is present (PWR)
Power load from local bus at 5V DC	Approx. 0,25W
Power load from local bus at 24V DC	Approx. 0,65W + 0,2W for reference output at full load
Total power dissipation	Approx. 0,9W + 0,1W for each input at max. level + 0,2W for reference output at full load
Max. current on V_S pin	1.5 A max.

Analog inputs	
Number of inputs	4, software configurable
Voltage inputs measuring range	0÷10 V
Voltage inputs typical impedance	280 kΩ typ
Voltage inputs digital resolution	12 bit
Voltage inputs total error at 25°C	±0.5% of full scale range
Voltage inputs temperature drift	<0.01%/°C (referred to full scale range)
Current inputs measuring range	0÷20 mA
Current inputs digital resolution	12 bit
Current inputs total error at 25°C	±0.75% of full scale range
Current inputs temperature drift	<0.02%/°C (referred to full scale range)
Inputs common potential isolation from GND	500 VAC, functional
Isolation between channels	none
Input state visual indicators	Two orange LED lamps for every input, switched on if input 0÷10 V (VPx) or input 4÷20 mA (IPx) is active

Reference output	
Nominal reference voltage	10 V
Output tolerance at 25°C	±0.5%
Output temperature drift	<0.01%/°C
Output current	40 mA max.

Interface	
Local bus	Proprietary FLXIO™
Module address setting	By rotary switch on front panel
Bus connections	By TBUS connectors on DIN rail
Interface circuitry protections	ESD protections
Level of ESD protection	±8 kV (IEC 61000-4-2, contact discharge)

Connections

The module has two connectors: a power connector and an I/O connector. They allow easy “plug and play” of the module, and also a fast replacement of a faulty unit.



Warning: Use a cable with cross-section suited to the current involved. A wire smaller than necessary could cause risk of fire and unwanted voltage drops.



Warning: To ensure conformance with EMC directive 2014/30/UE, the length of the cables must not exceed 30 m!



Warning: If the equipment is used in a manner not specified by the manufacturer, the protection provided by the equipment may be impaired

Power connector

The power connector is located on the bottom wall of the module. For the pinout, refer to the illustration.

Its function is to provide the supply for the I/O circuitry, whilst the CPU of the module is fed by the TBUS connector on the back of the unit.

Refer to the FLXIO and FLXMOD System Integration Manual for power connections topology.

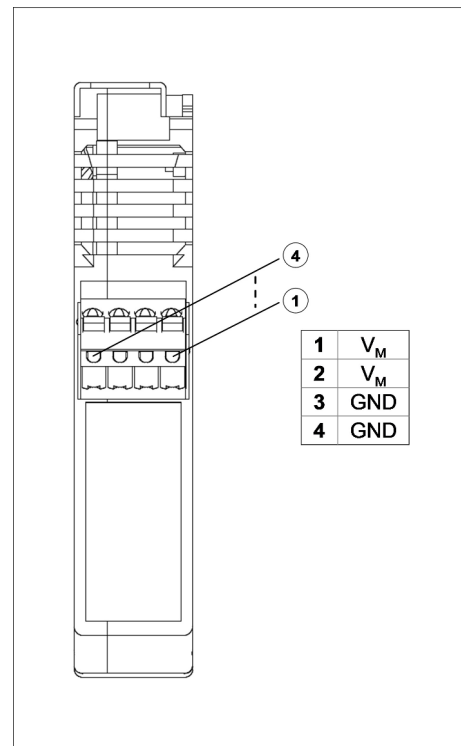

For connector ratings and the applicable wiring refer to the following table

Connector type: Phoenix Contact FKC 2,5/ 4-ST (1910377)			
Order code: KF100009			
Technical data		Conductor cross section	
Nominal voltage (CE)	250V	Solid (CE)	0,2÷2,5mm ²
Nominal voltage (UL)	300V	Solid (UL)	26÷12AWG - 75°C
Nominal current (CE)	12A	Flexible (CE)	0,2÷2,5mm ²
Nominal current (UL)	10A	Flexible (UL)	26÷12AWG - 75°C
		Flexible, with ferrule without plastic sleeve	0,25÷2,5mm ²
Stripping length	10mm	Flexible, with ferrule with plastic sleeve	0,25÷2,5mm ²
Screwdriver to open contacts	0,6 x 3,5mm	2 flexible conductors with same cross section, stranded, TWIN ferrules with plastic sleeve	0,5÷1,5mm ²



Warning: Pay attention to NOT supply the module with reverse polarity. This is to not blow internal fuse and/or damage the connected devices and/or burn the module itself.

Input connector

Located on the upper side of the module, this connector (see illustration) permits the wiring of the input signals.

As you can see from the illustration, each row of the connector has similar pinout, to ease the wiring and prevent mistakes.

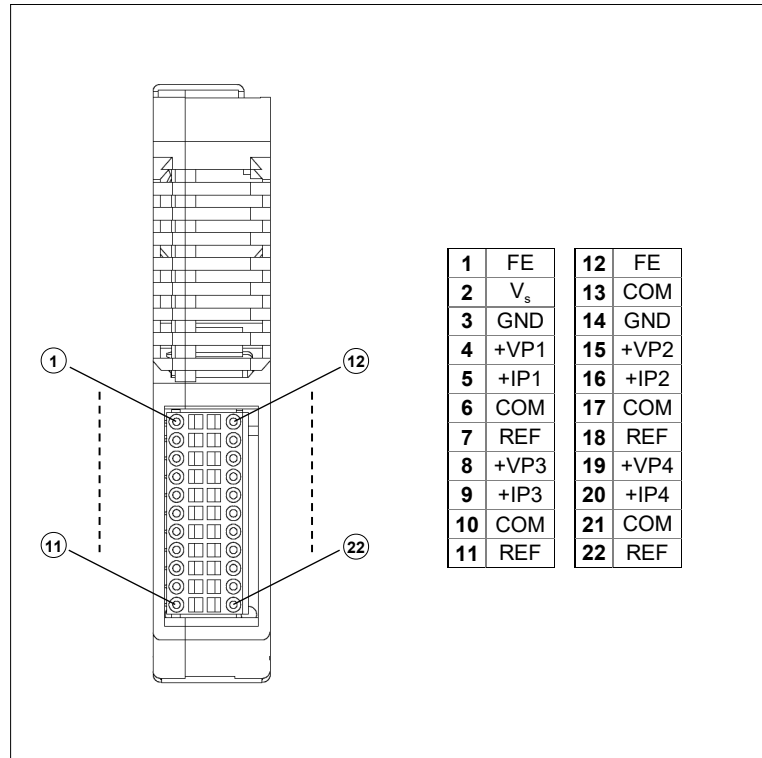

For connector ratings and the applicable wiring refer to the following table

Connector type: Phoenix Contact FMCD 1,5/11-ST-3,5 (1738898)			
Order code: KF101048			
Technical data		Conductor cross section	
Nominal voltage (CE)	160V	Solid (CE)	0,2÷1,5mm ²
Nominal voltage (UL)	150V	Solid (UL)	24÷16AWG - 75°C
Nominal current (CE)	8A	Flexible (CE)	0,2÷1,5mm ²
Nominal current (UL)	8A	Flexible (UL)	24÷16AWG - 75°C
Stripping length	10mm	Flexible, with ferrule without plastic sleeve	0,25÷1,5mm ²
Screwdriver to open contacts	0,4 x 2,5mm	Flexible, with ferrule with plastic sleeve	0,25÷0,75mm ²

Connection notes

The connection scheme differs slightly, depending on the sensor's technology. More precisely, you have to use a different wiring for 4-wire, 3-wire and 2-wire actuators.

In the figure on the next page, you'll find the recommended wiring for these sensors. If the system should work in a noisy environment, the use of shielded wire is mandatory; the shield must be connected to the FE pin of the connector.



Warning: If the supply for a sensor is drawn from the input connector, be careful not to exceed the maximum current, or the internal fuse will blow. Refer to the module characteristics for fuse ratings.



Warning: If the sensor is fed by an external power supply unit, never exceed the isolation voltage quoted on module characteristics, or system failure will occur!



Warning: Supplying a sensor with an external power supply unit, be aware of signal degradation risk due to quickly varying common mode potentials. Whenever possible, the ground of the external power supply should be equipotential with the ground of the main power supply.

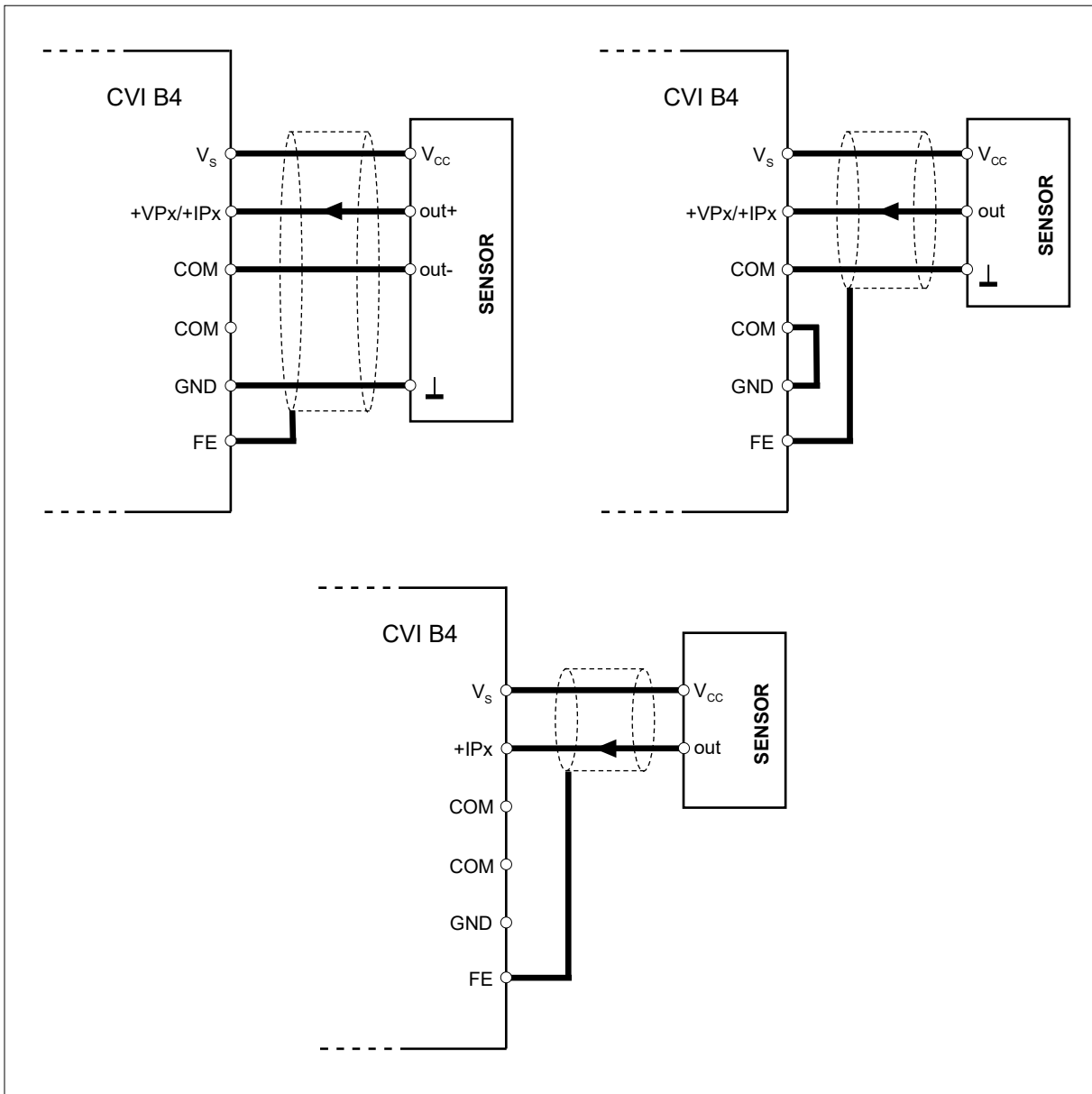

Recommended connection for sensors, using a 4-wire (above, on the left), 3-wire (above, on the right) and 2-wire (below, current sensors only) technique.

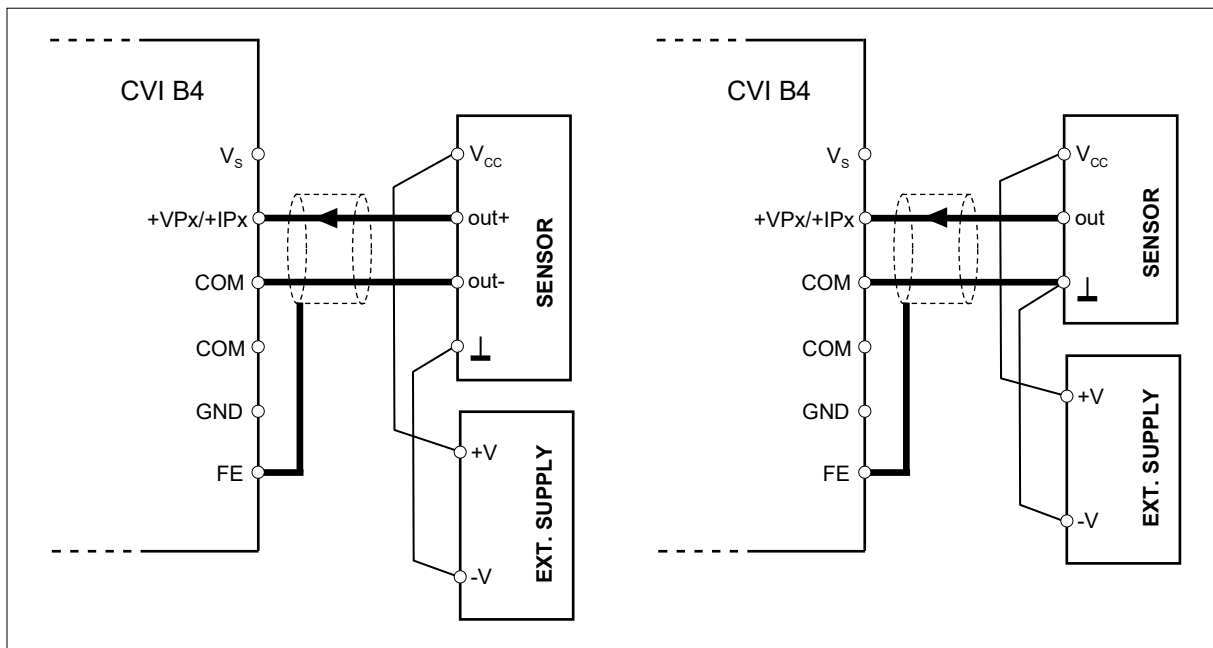

Recommended wiring for externally-fed sensors, having a differential (left) and single-ended (right) signal input.

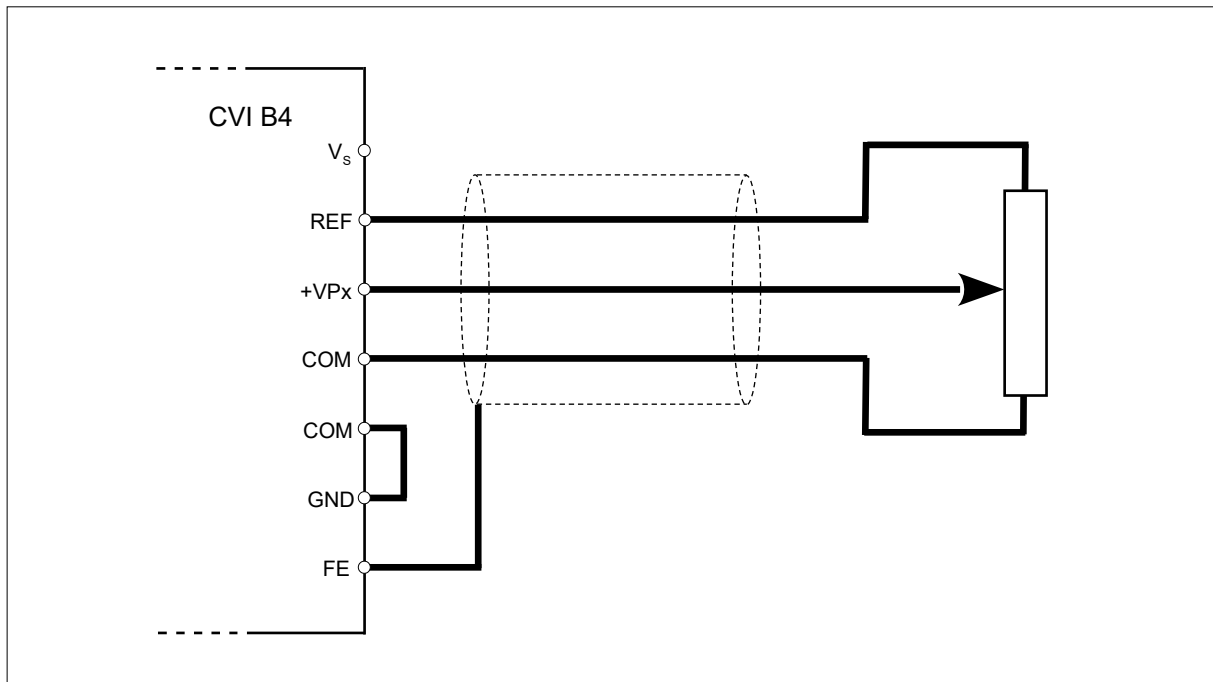

Recommended wiring for potentiometer acquisition, using internal 10V reference.

Module addressing

Before operation you must set the address of the module by the rotary switch reachable from the front panel; the operation is easily done opening the transparent plastic cover and turning the rotor with a small bladed screwdriver.

The address determination is described in the FLXIO and FLXMOD System Integration Manual.

Diagnostic and status indicators

Each module is provided with a series of LED lamps on the front panel (see illustration), indicating the status of the unit, the setting of every output (voltage or current) and a possible diagnostic warning. For the sake of clarity, different lamp colours are employed.

The green power (**PWR**) LED is lighted if the 24 V supply (V_M) is present and the internal fuse is not blown.

Self monitoring of supply voltage is also implemented to deliver a best self-diagnosis. The module switches in diagnostic error when $V_M > 30Vdc$ and when $V_M <$ of the value set up by the master module (low voltage check is disabled by default); this status is displayed by STS LED.

The **V_{Pi}** and **I_{Pi}** LEDs indicate that the input #**i** is set to acquire a voltage or a current signal respectively.

The status of the unit is indicated by both status (**STS**) and fault (**FLT**) LEDs; their behaviour is described in the following logic state chart. The exact cause of a diagnostic error can be read out by master module and the application software.

