

RTD A2

Module with 2 analog inputs for RTDs

Datasheet

Description

Module for the acquisition of Resistance Temperature Sensors (RTD), dual channel.
Main characteristics:

- 2 analog inputs for standard 100 Ω RTDs (PT100)
- Two and three-wire sensors
- 12 bit resolution
- Status and diagnostic LEDs

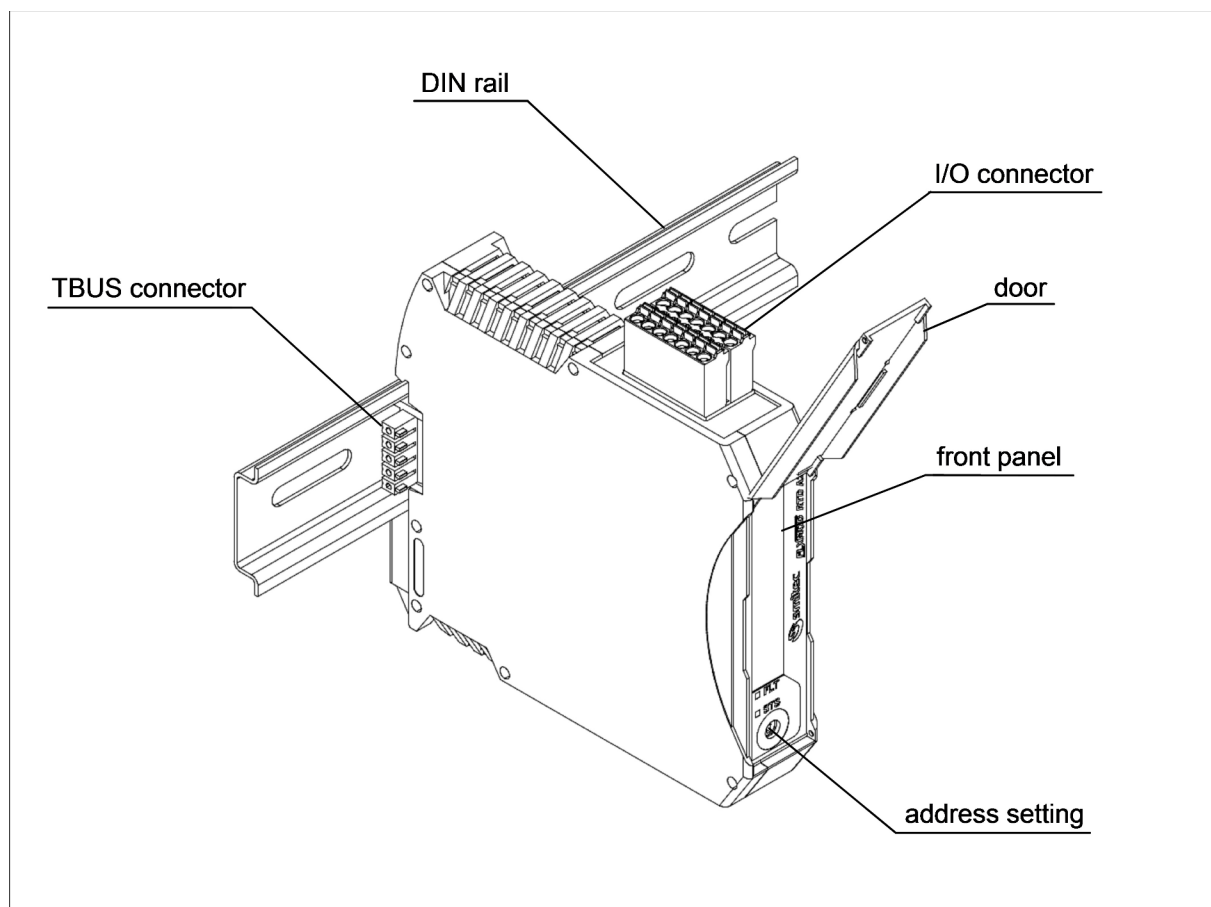

Ordering informations

Products	SMITEC part number
Module with 2 analog inputs, complete with accessories (inputs connector and TBUS connector)	KZ010210

Accessories	SMITEC part number
I/O connector (Phoenix Contact p/n 1738856)	KF101049
TBUS connector (Phoenix Contact p/n 2713722)	KF101034

Documentation	SMITEC part number
Installing instructions	DK400042
Datasheet for RTD A2	DK400073
FLXIO and FLXMOD system integration manual	DK400076

Technical data

General data	
Housing dimensions (width x height x depth)	22.5 mm x 99.0 mm x 114.5 mm
Weight	97 g (without connectors), 109 g (with connectors)
Connection method for connectors	Spring cage terminals
Conductor cross-section (output connector)	0.2 to 1.5 mm ² (24 ÷ 16 AWG)
Functional earth connection	To the DIN rail by spring contact
Mode state visual indicators	Fault (FLT) and status (STS) LED lamps

Environment data	
Permissible operating temperature	+5° to +55°C
Permissible storage and transport temperature	-25° to +85°C
Permissible humidity	10% to 95%, not condensing
Permissible air pressure (operation)	80 to 106 kPa (up to 2000 m above sea level)
Permissible air pressure (storage and transport)	70 to 106 kPa (up to 3000 m above sea level)
Degree of protection (CE)	IP20 according to IEC 60529
Degree of protection (UL)	Open Type
Overvoltage category	II
Pollution degree	2
Means of protection (UL)	Class III SELV power supply

Power supply	
Module power supply	5 VDC and 24 VDC from local bus
Power load from local bus at 5V DC	Approx. 0,25W
Power load from local bus at 24V DC	Approx. 0,65W
Total power dissipation	Approx. 0,9W

Analog inputs	
Number of inputs	2
Type of inputs	For standard two and three-wire PT100 Resistance Temperature Detectors (RTDs)
Sensor temperature range (nominal)	From -53° to +358°C
Sensor resistance range (nominal)	From 79 Ω to 232 Ω
Sensor bias current	930 μA
Sensor cables resistance compensation	Yes, with three-wire sensors
Inputs total error at 25°C	±0.5% of full scale range
Inputs temperature drift	<0.01%/°C (referred to full scale range)
Outputs common potential isolation from GND	500 VAC, functional
Isolation between channels	none
Input state visual indicators	none

Interface	
Local bus	Proprietary FLXIO™
Module address setting	By rotary switch on front panel
Bus connections	By TBUS connectors on DIN rail
Interface circuitry protections	ESD protections
Level of ESD protection	±8 kV (IEC 61000-4-2, contact discharge)

RTD sensors

RTD stands for Resistance Temperature Detector, a device showing a temperature-dependent characteristic. More in detail, these devices are made of a Platinum wire (or a Platinum film spread on a suited insulating layer) exhibiting a precisely repeatable resistance-versus-temperature characteristics.

Standard PT100 sensors have a $100\ \Omega$ resistance at 0°C , with a positive temperature coefficient of approximately $0.385\ \Omega/^{\circ}\text{C}$. Temperature sensing is accomplished measuring actual device resistance with a dedicated circuit, and converting resistance into temperature with a conversion table. Depending on desired measuring accuracy, three different sensor technologies are currently employed: two wire, three wire and four wire RTDs.

Two wire sensors are nothing more than a platinum resistor provided with two sensing wires; measuring device resistance is usually accomplished injecting a small amount of current (bias current) and measuring the voltage developed across the element. Accuracy of measure is affected by wires resistance, rendering this method unsuitable when long sensing wires are involved.

Overcoming this problem is possible adding a third wire to the sensor, making a so called three-wire RTD. With a specific designed circuit, it is possible to compensate for the resistance of sensing wires (and relative temperature drift), allowing the use of notably longer cables. A residual measuring error is due to the unavoidable difference of resistance between different sensor's wires. Principal drawbacks of this technique are the increase of the number of wires and the added complexity of the circuit.

Where high precision is a must, or when you have to cope with very long cables, you should use four wire sensors. Using a so called Kelvin connection, two wires are used for RTD biasing, when the remaining two wires are used to sense the voltage across the element. In this manner, the measure is virtually unaffected by the resistance of the wires. Most industrial applications are satisfied with cheaper two and three wire RTDs.

Connections

The module has only an input connector; it allows easy “plug and play” of the module, and also a fast replacement of a faulty unit.



Warning: Use a cable with cross-section suited to the current involved. A wire smaller than necessary could cause risk of fire and unwanted voltage drops.



Warning: To ensure conformance with EMC directive 2014/30/UE, the length of the cables must not exceed 30 m!



Warning: If the equipment is used in a manner not specified by the manufacturer, the protection provided by the equipment may be impaired

Input connector

Located on the upper side of the module, this connector (see illustration) permits the wiring of the sensors.

As you can see from the illustration, each row of the connector has the same pinout, to ease the wiring and prevent mistakes.

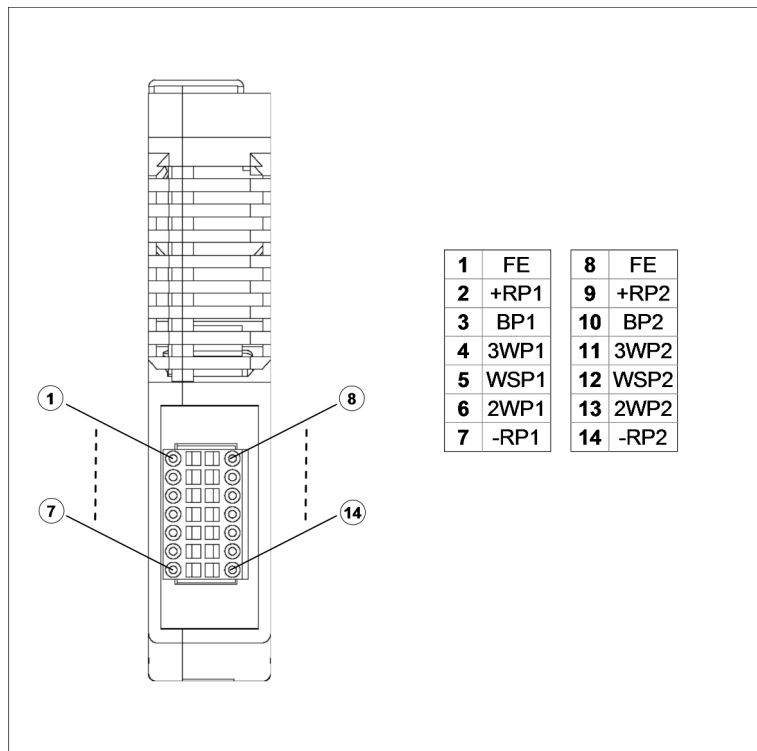

For connector ratings and the applicable wiring refer to the following table

Connector type: Phoenix Contact FMCD 1,5/7-ST-3,5 (1738856)			
Order code: KF101049			
Technical data		Conductor cross section	
Nominal voltage (CE)	160V	Solid (CE)	0,2÷1,5mm ²
Nominal voltage (UL)	150V	Solid (UL)	24÷16AWG - 75°C
Nominal current (CE)	8A	Flexible (CE)	0,2÷1,5mm ²
Nominal current (UL)	8A	Flexible (UL)	24÷16AWG - 75°C
Stripping length	10mm	Flexible, with ferrule without plastic sleeve	0,25÷1,5mm ²
Screwdriver to open contacts	0,4 x 2,5mm	Flexible, with ferrule with plastic sleeve	0,25÷0,75mm ²

Connection notes

The connection scheme differs slightly, depending on the sensor's technology. More precisely, you have to use a different wiring for two-wire and three-wire sensors.

In the figure on the next page, you'll find the recommended wiring for these sensors. Due to harsh industrial environment and small signals involved, the use of shielded wire is mandatory; the shield must be connected to the FE pin of the connector.

As you see in the illustration, WSPx pin should be connected to pin 3WPx if you use three-wire sensors; two-wire sensors need a connection between WSPx pin and 2WPx pin. If necessary, you can use a two-wire sensor on a channel and a three-wire sensor on the other, being the circuits independent each other.

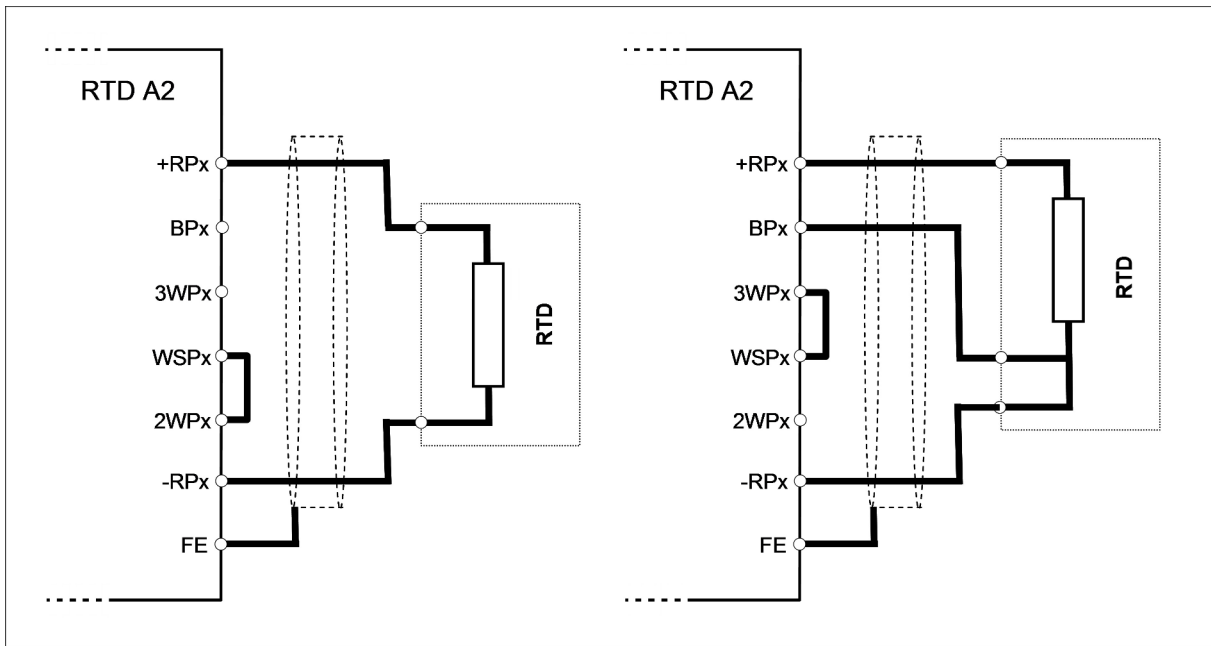

Recommended connection for two-wire (left) and three-wire (right) sensors

Module addressing

Before operation you must set the address of the module by the rotary switch reachable from the front panel; the operation is easily done opening the transparent plastic cover and turning the rotor with a small bladed screwdriver.

The address determination is described in the FLXIO and FLXMOD System Integration Manual.

Diagnostic and status indicators

The status of the unit is indicated by both status (STS) and fault (FLT) LEDs; their behaviour is described in the following logic state chart. The exact cause of a diagnostic error can be read out by master module and the application software.

