

TCP A3

Module with 3 thermocouple inputs

Datasheet

Description

Module for the acquisition of thermocouples, triple channel.

Main characteristics:

- 3 differential inputs for thermocouples
- 1 input for external LM335 sensor (cold junction)
- internal cold junction compensation available
- 12 bit resolution
- status and diagnostic LEDs

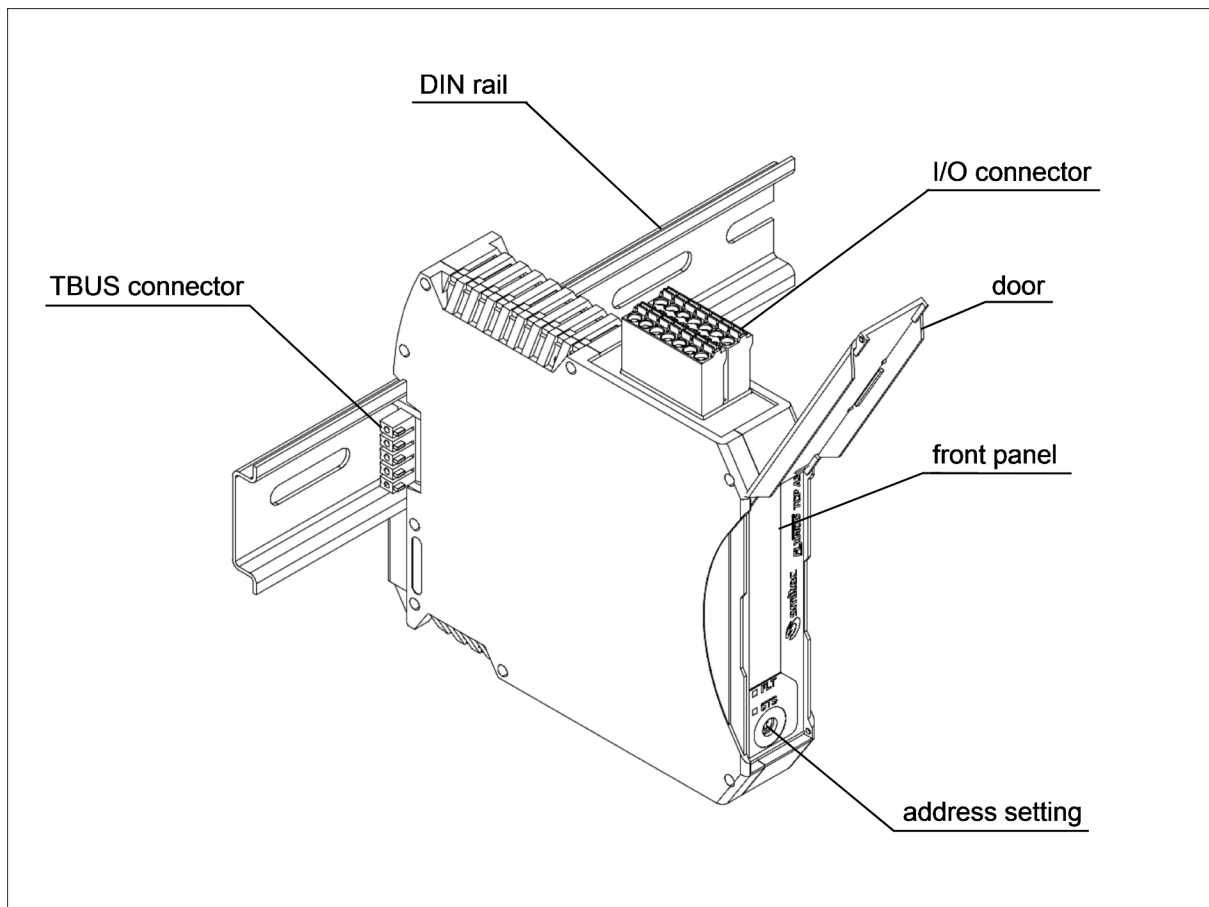

Ordering informations

Products	SMITEC part number
Module with 3 thermocouple inputs, complete with accessories (inputs connector and TBUS connector)	KZ010234
Module with 3 thermocouple high impedance inputs, complete with accessories (inputs connector and TBUS connector)	KZ010365
Module with 3 thermocouple reduced band inputs, complete with accessories (inputs connector and TBUS connector)	KZ010608

Accessories	SMITEC part number
I/O connector (Phoenix Contact p/n 1738856)	KF101049
TBUS connector (Phoenix Contact p/n 2713722)	KF101034

Documentation	SMITEC part number
Installing instructions	DK400042
Datasheet for TCP A3	DK400072
FLXIO and FLXMOD system integration manual	DK400076

Technical data

General data	
Housing dimensions (width x height x depth)	22.5 mm x 99.0 mm x 114.5 mm
Weight	96 g (without connectors), 108 g (with connectors)
Connection method for connectors	Spring cage terminals
Conductor cross-section (output connector)	0.2 to 1.5 mm ² (24 – 16 AWG)
Functional earth connection	To the DIN rail by spring contact
Mode state visual indicators	Fault (FLT) and status (STS) LED lamps

Environment data	
Permissible operating temperature	+5° to +55°C
Permissible storage and transport temperature	-25° to +85°C
Permissible humidity	10% to 95%, not condensing
Permissible air pressure (operation)	80 to 106 kPa (up to 2000 m above sea level)
Permissible air pressure (storage and transport)	70 to 106 kPa (up to 3000 m above sea level)
Degree of protection (CE)	IP20 according to IEC 60529
Degree of protection (UL)	Open Type
Overvoltage category	II
Pollution degree	2
Means of protection (UL)	Class III SELV power supply

Power supply	
Module power supply	5 VDC and 24 VDC from local bus
Power load from local bus at 5V DC	Approx. 0,25W
Power load from local bus at 24V DC	Approx. 0,65W
Total power dissipation	Approx. 0,9W

Thermocouple inputs	
Number of inputs	3
Input voltage range (nominal)	-2.582 mV ÷ +28.405 mV
Input resolution	12 bit / 7.56533 µV
Input temperature range (thermocouple J)	-53.24°C ÷ +518.04°C
Input temperature range (thermocouple K)	-69.85°C ÷ +682.74°C
Input temperature range (thermocouple E)	-46.11°C ÷ +393.24°C
Input temperature range (thermocouple R)	-50°C ÷ +1768°C
Input temperature range (thermocouple S)	-50°C ÷ +1768°C
Input temperature range (thermocouple T)	-73.35°C ÷ +400°C
Input temperature range (thermocouple B)	+50°C ÷ +1820°C
Input temperature range (thermocouple N)	-108.52°C ÷ +798.74°C
Input temperature range (thermocouple C)	0°C ÷ +1611.47°C
Inputs total error at 25°C	±0.5% of full scale range
Inputs temperature drift	<0.01%/°C (referred to full scale range)
Outputs common potential isolation from GND	500 VAC, functional
Isolation between channels	none
Input state visual indicators	none
Input impedance KZ010234 and KZ010608	10 MΩ
Input impedance KZ010365 (no pull-up resistor)	> 1 GΩ
Input frequency band KZ010234 and KZ010365	Max 750 kHz
Input frequency band KZ010608	Max 3.4 Hz

Cold junction input	
Input voltage range (nominal)	2.227 V ÷ 3.727 V
Input resolution	12 bit / 366.21 µV / 0.036621°C
Temperature sensor	LM135 / LM235 / LM335
Internal temperature sensor	LM335, selectable with jumper on input connector
Input temperature range	-50.3°C ÷ +99.7°C
Input total error at 25°C	±1% of full scale range
Input temperature drift	<0.02%/°C (referred to full scale range)
Outputs common potential isolation from GND	500 VAC, functional
Input state visual indicators	none

Interface	
Local bus	Proprietary FLXIO™
Module address setting	By rotary switch on front panel
Bus connections	By TBUS connectors on DIN rail
Interface circuitry protections	ESD protections
Level of ESD protection	±8 kV (IEC 61000-4-2, contact discharge)

Thermocouples

A thermocouple is a device made joining two different metals together; the joint so obtained shows a precisely repeatable temperature-depending characteristic. More in detail, a thermocouple behaves like a low-impedance voltage generator, whose amplitude is related to the difference of temperature between the joint and the point where the wires are connected to the measuring instrument (usually named cold junction). In other words, the thermocouple measures only a difference of temperature; measuring the absolute temperature of the joint involves the knowledge of the cold junction temperature. Even if it is possible to force the temperature of the cold junction at a known level (e.g. immersing the cold junction in an ice bath, at 0°C), in industrial applications the temperature of the cold junction is usually measured with semiconductor sensors, NTCs or RTDs.

Temperature measurement is generally accomplished measuring the voltage across the terminals with a low-offset amplifier (typical thermocouple signals have an amplitude of 10 ÷ 50 μV/°C); differential temperature is obtained converting the measured value in degrees using a lookup table (the temperature vs. voltage characteristic is notably nonlinear).

The temperature of the cold junction is sensed with a dedicated LM335 semiconductor sensor, sold by National Semiconductor and STMicroelectronics. Available in different precision grades, it behaves like a Zener diode having a breakdown voltage proportional to the absolute temperature of the chip. The ideal characteristic of the sensor is:

$$V_{LM335} = k \cdot T_{ABSOLUTE}$$

where k is the “gain” of the sensor (10 mV/K) and $T_{ABSOLUTE}$ is the absolute temperature of the chip, expressed in Kelvin. At 25°C, the breakdown voltage is 2.98 V. As any Zener diode, it needs a bias current (usually about 1 mA) to work properly.

The absolute temperature is obtainable adding the temperature of the cold junction to the differential temperature of the thermocouple.

Connections

The module has only an input connector; it allows easy “plug and play” of the module, and also a fast replacement of a faulty unit.



Warning: Use a cable with cross-section suited to the current involved. A wire smaller than necessary could cause risk of fire and unwanted voltage drops.



Warning: To ensure conformance with EMC directive 2014/30/UE, the length of the cables must not exceed 30 m!



Warning: If the equipment is used in a manner not specified by the manufacturer, the protection provided by the equipment may be impaired

Input connector

Located on the upper side of the module, this connector (see illustration) permits the wiring of the sensors.

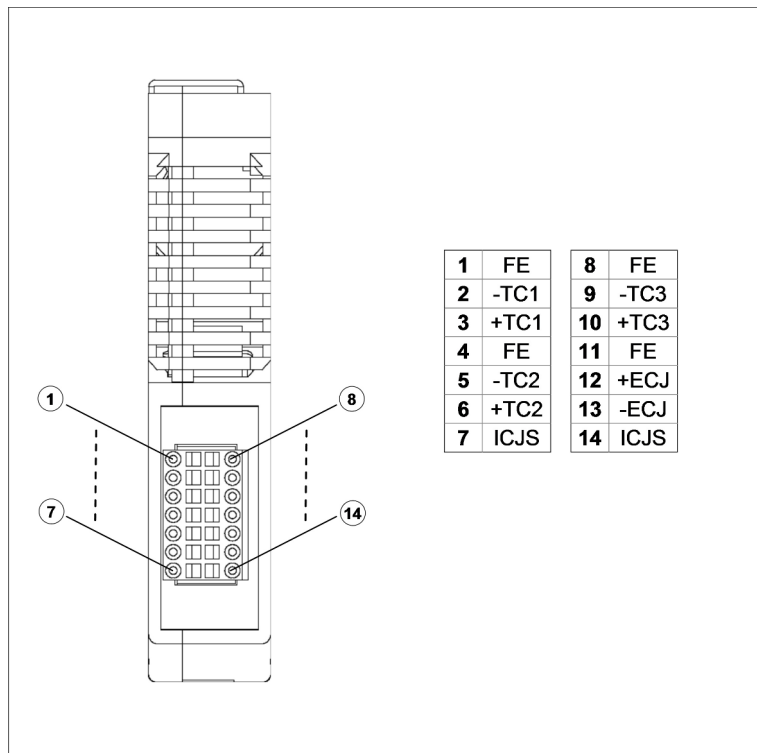

For connector ratings and the applicable wiring refer to the following table

Connector type: Phoenix Contact FMCD 1,5/7-ST-3,5 (1738856)			
Order code: KF101049			
Technical data		Conductor cross section	
Nominal voltage (CE)	160V	Solid (CE)	0,2÷1,5mm ²
Nominal voltage (UL)	150V	Solid (UL)	24÷16AWG - 75°C
Nominal current (CE)	8A	Flexible (CE)	0,2÷1,5mm ²
Nominal current (UL)	8A	Flexible (UL)	24÷16AWG - 75°C
Stripping length	10mm	Flexible, with ferrule without plastic sleeve	0,25÷1,5mm ²
Screwdriver to open contacts	0,4 x 2,5mm	Flexible, with ferrule with plastic sleeve	0,25÷0,75mm ²

Connection notes

In the figures on the following pages, you'll find the recommended wiring for these sensors. Due to harsh industrial environment and small signals involved, the use of shielded wire is mandatory; the shield must be connected to the FE pin of the connector.

When using an external cold junction sensor, be careful to avoid any difference of temperature between sensor and cold junction or between adjacent thermocouples. If you use the internal cold junction sensor, connect the thermocouple wires directly on the connector. Where accuracy is critical, use selected LM335 sensor (available with the "A" suffix) and/or calibrate them using a 10k trimmer (see illustration); you should have 2.98 V at 25°C.

If thermocouple wires are shorter than necessary, purposely made extension cables are available, realised with the same metals.



Warning: Avoid using a standard copper wire for carrying a thermocouple signal before the cold junction box or the I/O connector (whenever you use the internal cold junction sensor), or it will lead to unpredictable measuring errors.



Warning: When non-insulated thermocouples are used, be careful to reduce common-mode disturbing voltages between FE and the tip of the thermocouples. These unwanted signals could degrade measuring accuracy and, in extreme cases, damage the internal circuitry. High-precision measurements are obtainable only using insulated thermocouples.

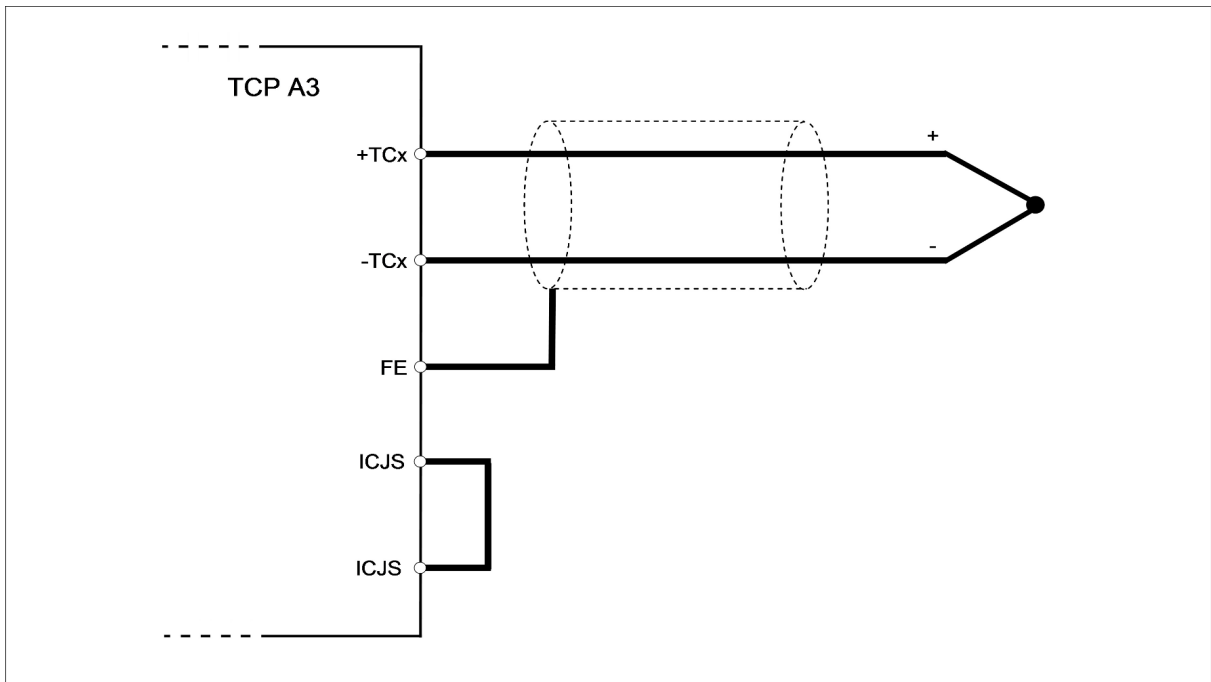

Recommended connections for thermocouples, using internal cold junction sensor.

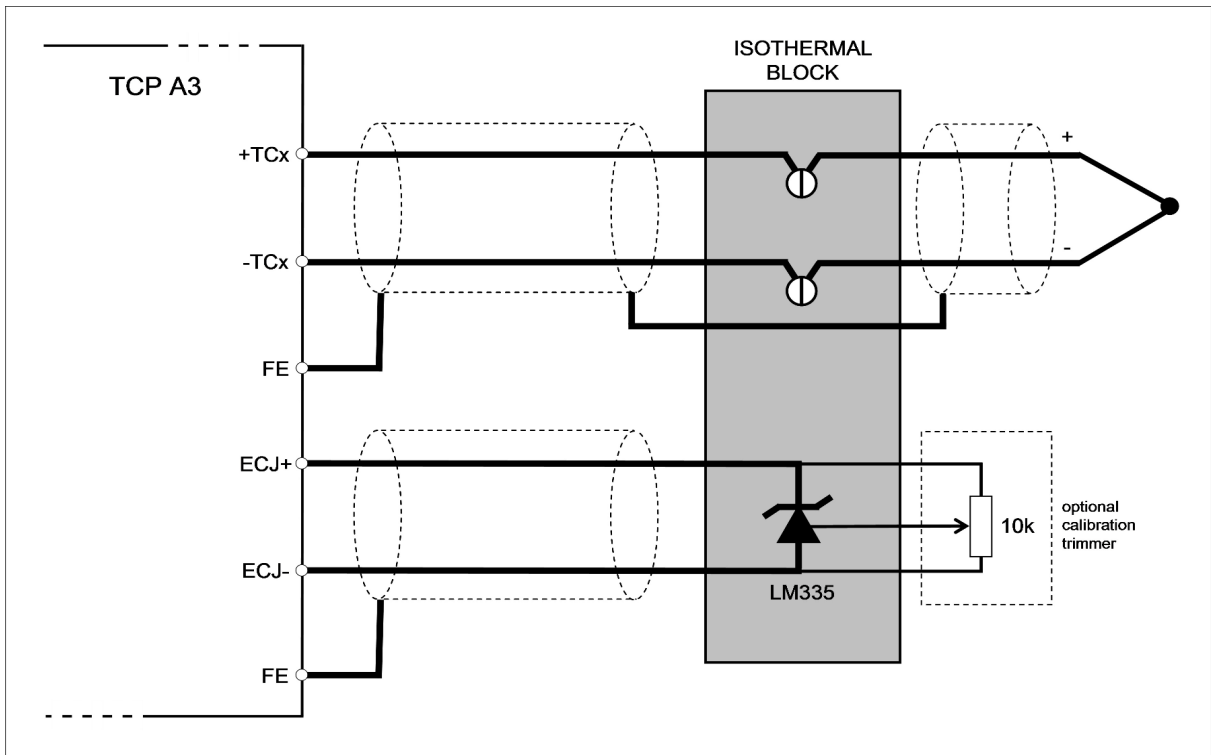

Recommended connections for thermocouples, using external cold junction sensor and junction box.

Notes on internal cold junction compensation

When cold junction compensation is attained using internal temperature sensor, any difference in temperature between cold junction and internal temperature sensor is responsible to measurement inaccuracy. Great care must be taken to reduce temperature gradients between the connector (cold junction) and temperature sensor (mounted on PCB board inside the module).

Whenever possible, try to apply the following rules:

- Mount the module well away from heat/cold sources (e.g. power resistors, motors, fans or blowers, inverters, power supplies, etc..).
- Avoid embedding the module between two power modules (e.g. PWR 01, MDR A2, DPO A4, etc..), as they generate a noticeable amount of heat.
- When the preceding condition is unavoidable (e.g. for space constraints or due to layout of the electric cabinet), leave an empty position between adjacent modules as an air gap.
- Wires are good heat conductors; route them well away from heat/cold sources. Whenever applicable, reduce the wire cross-section to impair heat conduction along wires.

If greater accuracy is needed, or when the preceding conditions are not applicable due to special constraints, external cold junction compensation is mandatory.

Module addressing

Before operation you must set the address of the module by the rotary switch reachable from the front panel; the operation is easily done opening the transparent plastic cover and turning the rotor with a small bladed screwdriver.

The address determination is described in the FLXIO and FLXMOD System Integration Manual.

Diagnostic and status indicators

The status of the unit is indicated by both status (STS) and fault (FLT) LEDs; their behaviour is described in the following logic state chart. The exact cause of a diagnostic error can be read out by master module and the application software.

Using the TCP A3 module with standard inputs (not the high impedance version) it is possible to detect a broken thermocouple or broken wire by reading the relative input value; when the reading reach the positive full scale value, the thermocouple or its wire may be broken.

In the TCP A3 module with high impedance inputs, in case of thermocouple or wire break, the relative input read value may be random.

