

HMI A2

FLXMOD

Machine interface

Description

FLXMOD™ system machine interface module, equipped with a 20x4 alphanumeric display and a 13 buttons keyboard. This unit, designed for panel mounting and housed in a rugged metal case, is designed especially to work in conjunction with a FLXMOD system.



Smitec S.p.A.
Viale Vittorio Veneto, 4 - 24016 San Pellegrino Terme (BG) ITALY
Tel. +39 0345 40.800 - Fax: +39 0345 40.809 - www.smitec.it
Head office:
Via Carlo Ceresa, 10 - 24015 San Giovanni Bianco (BG) ITALY
C.F. e P. IVA IT03790400166

Technical data	
Housing material	Aluminum and steel
Degree of protection	IP65 (when flush mounted)
Display	Monochromatic (white over blue) 20 characters x 4 rows
Keyboard	13 buttons
Connections	RJ45 (available in cascable version)
Electrical specifications	Power supply: 24V _{DC}
Environmental specifications	Operating temperature: from +5°C to +55°C Storage temperature: from -25°C to +85°C Relative humidity: from 10% to 95% (non-condensing)

Dimensions

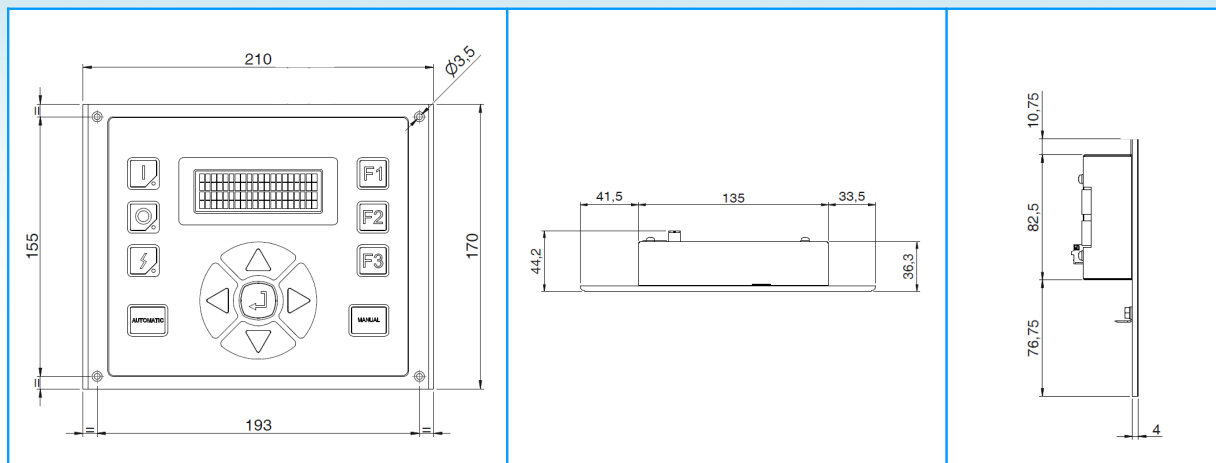

Data here mentioned are subject to changes without any notice.