

Smitec S.p.A., viale Vittorio Veneto 4, 24016 San Pellegrino Terme (BG), Italy, www.smitec.it



Installation, use and maintenance manual



BEFORE PUTTING INTO SERVICE THE POWER SUPPLY UNITS OF THE ICOS-PS 3160 SERIES, CAREFULLY READ THIS MANUAL AND FOLLOW ALL INSTRUCTIONS, IN ORDER TO ENSURE MAXIMUM SAFETY

POWER SUPPLY UNITS ICOS-PS 3160 SERIES



The technical data and the drawings in this manual might have been modified later; always refer to the latest version.

Summary

1 Preface	4
2 General warnings	5
3 Safety instructions	7
3.1 General information	7
3.2 Precautions during handling and assembly	7
3.3 Precautions against the risk of Electric Shock	8
3.4 Precautions against contact with hot parts	8
3.5 Residual risks	9
4 Technical data	10
4.1 Environmental specifications	10
4.2 Power supply	11
4.3 DC output	11
4.4 Dynamic brake output	11
4.5 Digital I/O	12
4.6 Order codes	12
4.7 Accessories	12
4.8 Mechanical specifications	13
4.8.1 Weight	13
4.8.2 Overall dimensions	13
5 Installation and putting into service	14
5.1 Preliminary operations	14
5.2 Installation mode	15
5.3 Positioning and fastening	16
5.4 Connections	18
5.4.1 Upper view	18
5.4.2 Front view	19
5.4.3 Bottom view	20
5.5 Mains power supply - J1	21
5.5.1 Connection schematic	24
5.5.2 Conductors and protective devices	26
5.5.2.1 Protection for UL applications	26
5.5.2.2 Protection for other applications	26
5.5.3 EMI filtering	27
5.6 Braking/discharge resistor output - J2	29
5.7 DC BUS output - J3	31
5.8 Auxiliary power and I/Os - CTR	34
5.8.1 Power supply setting	35
5.8.2 Interface I/Os	36
5.9 Reactor - J4	38
5.10 Status LEDs	44
6 Operation and diagnostics	46
6.1 General status	46
6.2 Capacitors charging	47
6.3 Anomalies during the charging phase	48
6.4 Working operation and possible anomalies	49
6.5 Dynamic braking	53
6.6 Missing phase	54
6.7 Automatic capacity discharge operation (ICOS-PS 3162 only)	54
6.8 Digital input: RESET	55
7 Storage	56
8 Maintenance	57
8.1 Replacement of the charging resistor	58

9 Decommissioning and disposal	59
10 Analytical index	60

1 Preface

This manual provides all necessary information for the installation, use and maintenance of the power supply units ICOS-PS 3160.

The instructions included in this manual are addressed to the following professionals:

User	User is a person, a company or an institution that buys the equipment and uses it for the purposes it was designed for.
User/operator	User or operator is a person authorized by the user to operate on the equipment.
Specialized personnel	It refers to all persons with specific competence, able to recognize and avoid the dangers deriving from the use of the equipment.

The present instructions must be made available to all the above individuals.





2 General warnings



These assembly instructions are an integral part of the equipment, and must be kept for future reference until it decommissioned.

The user should be informed that the present instructions reflect the state of the art at the moment when the equipment was sold; they will remain fully acceptable despite subsequent upgrades based on new technical update.

	<p>DO NOT USE THE EQUIPMENT, NOR MAKE ANY INTERVENTION BEFORE INTEGRALLY READING AND UNDERSTANDING THIS MANUAL.</p>
<p>IN PARTICULAR, ADOPT ALL SAFETY PRECAUTIONS AND PRESCRIPTIONS INDICATED IN THIS MANUAL.</p>	
<p>THE EQUIPMENT MUST NOT BE USED FOR PURPOSES DIFFERENT THAN THE ONES DESCRIBED IN THIS MANUAL; SMITEC S.p.A. SHALL NOT BE HELD RESPONSIBLE FOR ANY DAMAGES, INCONVENIENCES OR ACCIDENTS DUE TO THE NON-COMPLIANCE WITH THESE PRESCRIPTIONS.</p>	

In order to make the manual consultation easier, the following symbols have been adopted:

	<p>Indication of "PROHIBITED ACTION".</p>
	<p>The symbol "DANGER" is used when non-compliance with the prescriptions or misuse may cause serious injuries.</p>
	<p>The symbol "DANGER FROM HOT SURFACES" is used when non-compliance with the prescriptions or misuse may cause serious injuries.</p>
	<p>The symbol "DANGER FROM ELECTRICAL SHOCK" is used when non-compliance with the prescriptions or misuse may cause serious injuries.</p>



	The symbol "USE OF INDIVIDUAL PROTECTIONS" means that protective gloves must be worn.
	The symbol "USE OF INDIVIDUAL PROTECTIONS" means that protective glasses must be worn.
	Indication of "INFORMATION OF PARTICULAR RELEVANCE".

The safety requirements are intended to define a series of behaviors and obligations to be followed in carrying out the activities listed below.



These prescriptions constitute the prescribed method of operating the device, in a way that is safe for personnel, equipments and environment.

3 Safety instructions

3.1 General information

	<p>Do not install or use the equipment before integrally reading and understanding this manual. In case of difficulties of interpretation, contact SMITEC technical service.</p> <p>It is absolutely forbidden to use the equipment for different purposes than the ones described in this manual. The technical data and the drawings in this manual might have been modified later; always refer to the latest version. All upgrades can be requested to SMITEC S.p.A. directly.</p>
	<p>Make sure that the personnel is qualified and adequately informed about the risks he may run and how to avoid them.</p>

3.2 Precautions during handling and assembly

	<p>Use adequate tools during the assembly, in order to avoid crushing or abrasions.</p>
	<p>Metal components and sharp surfaces may cause cuts and tears. In case of contact, be very careful and wear the personal protection equipment.</p>

3.3 Precautions against the risk of Electric Shock

	<p>All connectors on the equipment except for the interface connector (CTR) are potentially connected to dangerous voltages. Pay attention, to avoid danger of Electric Shock.</p>
	<p>During all phases of installation and maintenance of the equipment, disconnect it safely from the power supply network. Electric Shock risk.</p>
	<p>Some components of the apparatus (for example: the aluminium heatsink) are made of conductive materials. They must be connected securely to the protective conductor (PE/ Ground) using the appropriate terminals, to avoid risk of Electric Shock.</p>
	<p>Internally, the apparatus mounts the capacitors that retain a dangerous potential for at least 10 minutes after switching off. Before any operation, make sure that it has been disconnected from the network for at least 10 minutes.</p>
	<p>Never use the device partially or totally disassembled. Danger of Electric Shock and / or damage to persons and property.</p>

3.4 Precautions against contact with hot parts

WARNING

	<p>The heat sink of this device may become hot during its service: Hot Surface, Risk of Burn.</p>
---	---

AVERTISSEMENT

	<p>Le dissipateur thermique de cet appareil peut chauffer pendant son utilisation: Surface Chaude, Risque de Brûlure.</p>
---	---

	<p>By using the power supply in the construction of a machine, the manufacturer must take all precautions to avoid the operator's contact with the hot parts, to avoid the risk of burns.</p>
	<p>The braking resistor can reach high temperatures; implement all the precautions necessary to prevent the danger of burns.</p>

3.5 Residual risks

	<p>The apparatus generates an electromagnetic field during operation. Danger for people with pacemakers, metal prostheses or hearing aids.</p>
---	--

4 Technical data

4.1 Environmental specifications

Operating temperature (Maximum surrounding air temperature)	0° ÷ +45°C with full-load operation																
	0° ÷ +55°C with current derating																
Environment of use	Use in Pollution degree 2 Environment																
Degree of protection	IP20																
Air humidity during operation	5 ÷ 85% non condensing																
Storage temperature	-25°C ÷ +55°C																
Air humidity during storage	5 ÷ 95%																
Output current derating depending on the environmental temperature	<table border="1"> <caption>Output current derating vs. environmental temperature</caption> <thead> <tr> <th>T [°C]</th> <th>Pout [%]</th> </tr> </thead> <tbody> <tr><td>0</td><td>100.0</td></tr> <tr><td>10</td><td>100.0</td></tr> <tr><td>20</td><td>100.0</td></tr> <tr><td>30</td><td>100.0</td></tr> <tr><td>40</td><td>100.0</td></tr> <tr><td>50</td><td>80.0</td></tr> <tr><td>55</td><td>70.0</td></tr> </tbody> </table>	T [°C]	Pout [%]	0	100.0	10	100.0	20	100.0	30	100.0	40	100.0	50	80.0	55	70.0
T [°C]	Pout [%]																
0	100.0																
10	100.0																
20	100.0																
30	100.0																
40	100.0																
50	80.0																
55	70.0																
Maximum altitude	1000 m a.s.l., at rated output current																
	2000 m a.s.l., with current derating																
Output current derating depending on the altitude	<table border="1"> <caption>Output current derating vs. altitude</caption> <thead> <tr> <th>h [m]</th> <th>Pout [%]</th> </tr> </thead> <tbody> <tr><td>0</td><td>100.0</td></tr> <tr><td>1000</td><td>100.0</td></tr> <tr><td>2000</td><td>90.0</td></tr> </tbody> </table>	h [m]	Pout [%]	0	100.0	1000	100.0	2000	90.0								
h [m]	Pout [%]																
0	100.0																
1000	100.0																
2000	90.0																

4.2 Power supply

Mains voltage	230V AC $\pm 15\%$ 50/60 Hz
Type of power supply	Single-phase or three-phase
Maximum short-circuit current	5 kA at the installation point
Mains power supply absorption	28.2A RMS (single-phase power supply)
	26.5A RMS (three-phase power supply)
Auxiliary mains voltage	24V DC $-15 \div +20\%$
Auxiliary mains power supply max. absorption	30mA



The input current strictly depends on the line impedance; the values refer to sinusoidal mains with generator impedance equal to zero. In real cases, the input current may undergo a reduction up to 30%.

4.3 DC output

Rated voltage	325V DC not stabilized
Max output current	16.0A (three-phase power supply)
	9.0A (single-phase power supply)
Max output power	5.0 kW (three-phase power supply)
	2.8 kW (single-phase power supply)

4.4 Dynamic brake output

Braking resistor value range	20 Ω min.
Max braking power	About 10 kW
Average braking power	5 kW

4.5 Digital I/O

Reset	24V digital input. Device reset.
Power good	24V digital output. It indicates the device status.
Alarm	24V digital output. It indicates alarm conditions of the device.
1PH/3PH setting	Jumper inputs. Single-phase or three-phase operation setting.

4.6 Order codes

Order codes	Model	Description
KZ010451	ICOS-PS 3161	325VDC power supply unit for servodrives.
KZ010628	ICOS-PS 3162	325VDC power supply unit for servodrives with automatic discharge

4.7 Accessories

The power supply units of the ICOS-PS 3160 series are supplied with a complete series of detachable connectors for power supply and I/Os connection. The connectors can also be ordered separately, like other not included accessories. Here are the order codes:

Order code	Item
KF101042	230 VAC power connector
KF101043	Brake resistor connector
KG020099	DC BUS output connector with "L+ L-" label
KG020100	Reactor connector with "X X" label
KG020102	Auxiliary power supply and I/O connector with label
KG020098	39Ω capacitors charging resistor, wound on mica, complete with support

4.8 Mechanical specifications

4.8.1 Weight

The following table indicates the weight of the different models, including all detachable connectors:

Type	Weight (kg)
KZ010451	2.2
KZ010628	2.2

4.8.2 Overall dimensions

External size of the device only, without detachable connectors.

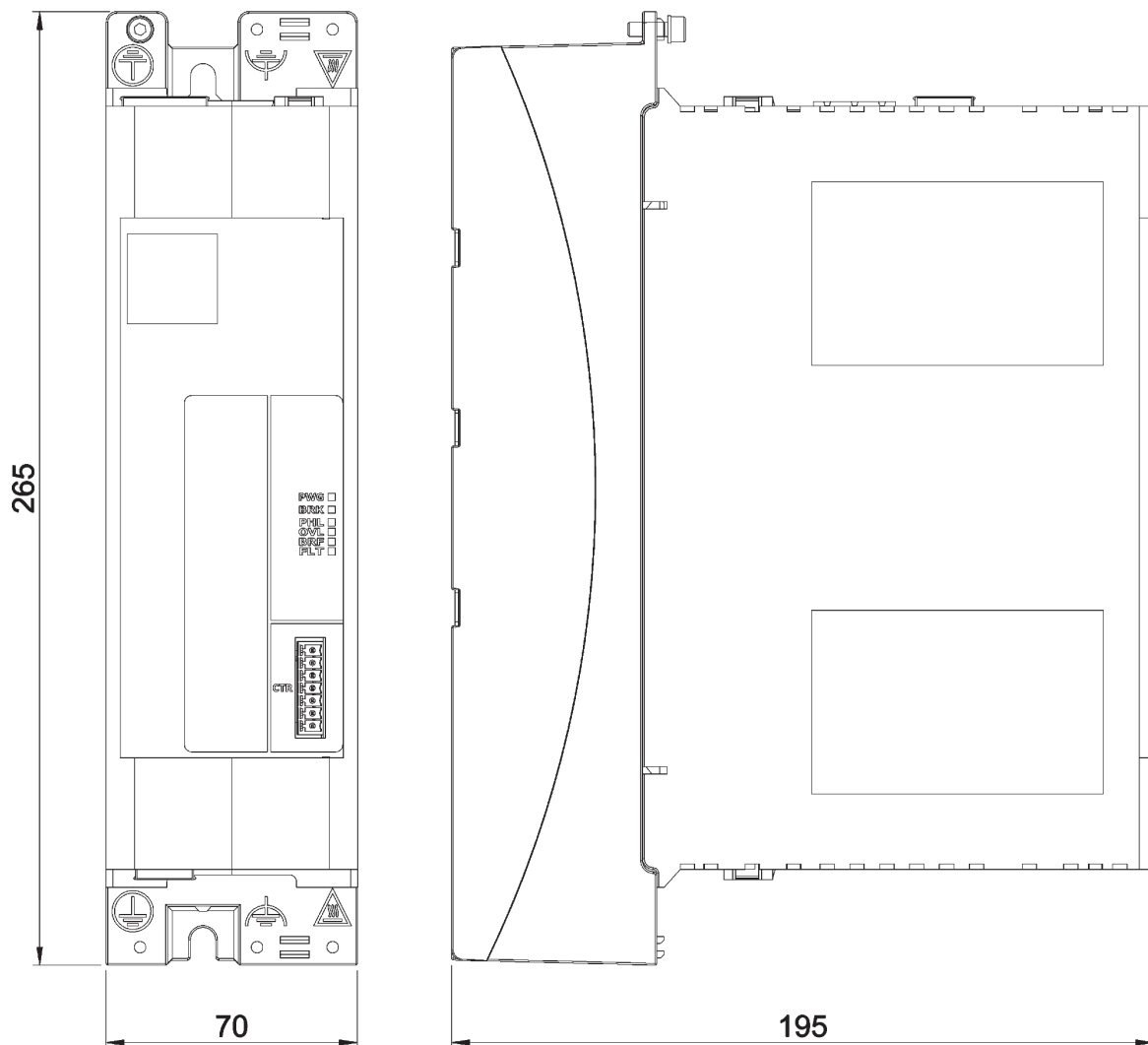

5 Installation and putting into service

5.1 Preliminary operations

Before putting into service the device, make the following checks:

- check the perfect integrity of the device and its components;
- make sure that all manuals necessary for installation are available;
- read and understand this manual integrally.

WARNING



Metal parts and all "live" parts can under certain conditions cause cuts and tears. Pay particular attention in case of contact and use suitable personal protective equipment (PPE).

AVERTISSEMENT



Les pièces métalliques et toutes les pièces sous tension peuvent, dans certaines conditions, provoquer des coupures et des déchirures. Portez une attention particulière en cas de contact et utilisez un équipement de protection individuelle (EPI) approprié.

WARNING



Use adequate tools during the assembly, in order to avoid crushing or abrasions.

AVERTISSEMENT



Lors du montage de l'appareil, utilisez des outils appropriés pour éviter tout risque de blessure, d'écrasement, d'abrasion, etc.

5.2 Installation mode

During the installation of the device, the upper and lower part must have a free space of at least 100 mm compared to other components or to the walls of the electrical panel, while other components can be placed alongside the ICOS-PS 3160 power supply without leaving any space.

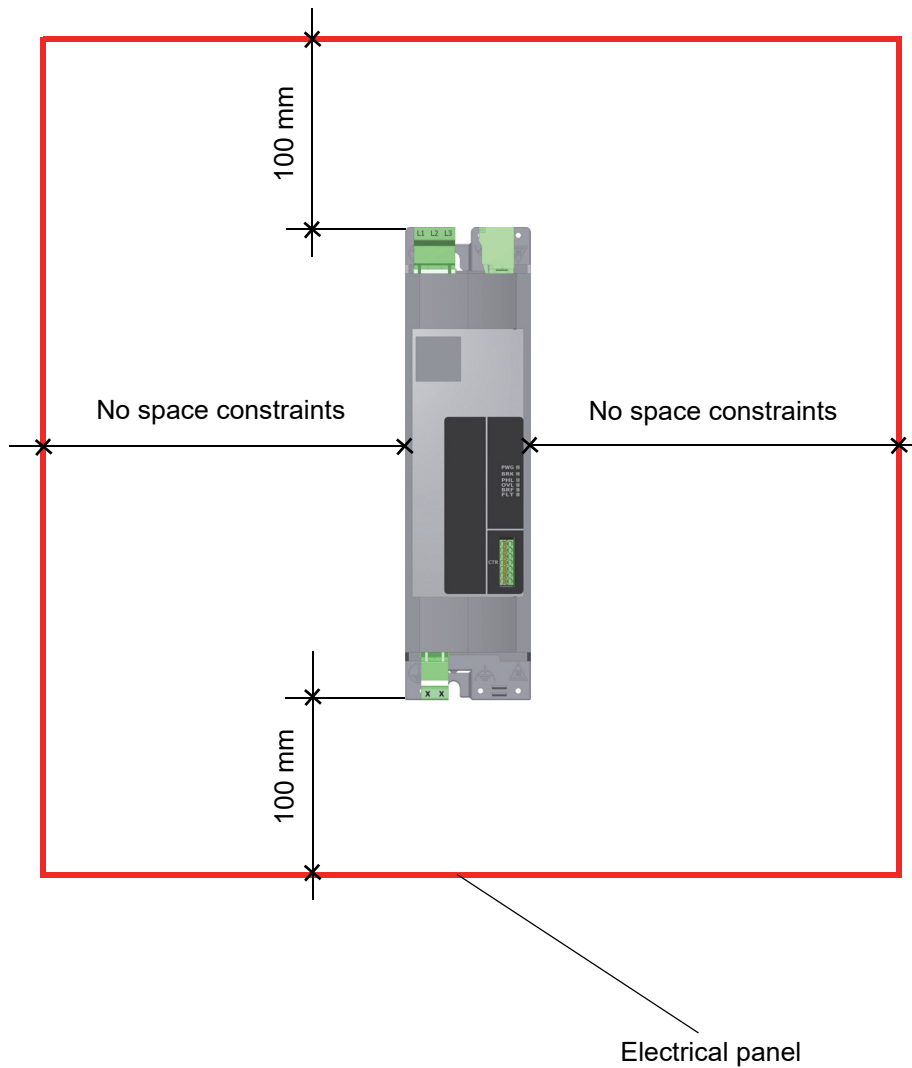

5.3 Positioning and fastening

The device must be fastened to a vertical wall inside the electrical panel; the heat sink is provided with two slots for screws having metric ISO thread M5.



The power supply units ICOS-PS 3160 are designed to operate in enclosed electrical operating areas (according to EN 61800-5-1); “at sight” installation outside an electrical panel is not allowed.

Tighten the screws (the tightening torque depends on the holding panel and on the type of screw); it is recommended to use locking washers (Grover or Belleville) or apply a medium strength thread locking compound (Loctite type 243 or equivalent) on the bolt shank.

The picture here below shows the position of the holes to be arranged in the holding panel.

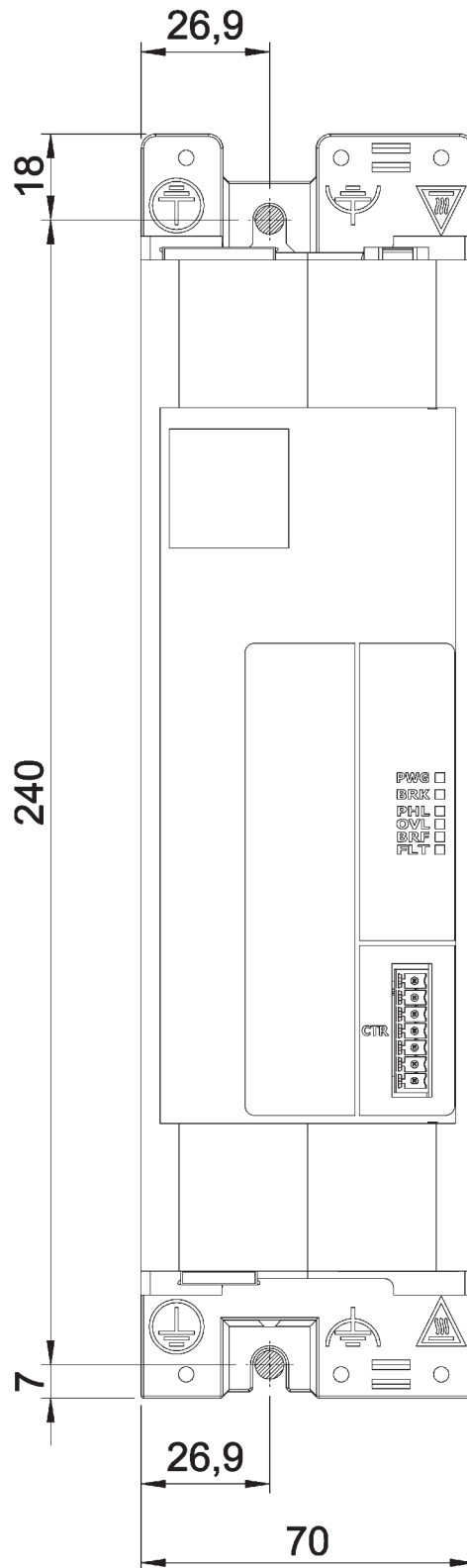

5.4 Connections

Electrical connections are ensured by detachable connectors, except for the connection PE (Ground), which must be connected by means of an eyelet crimp terminal and a suited fastening screw.

The following paragraphs describe the connectors position.

5.4.1 Upper view

The following picture shows the connections available on the upper face of the device:

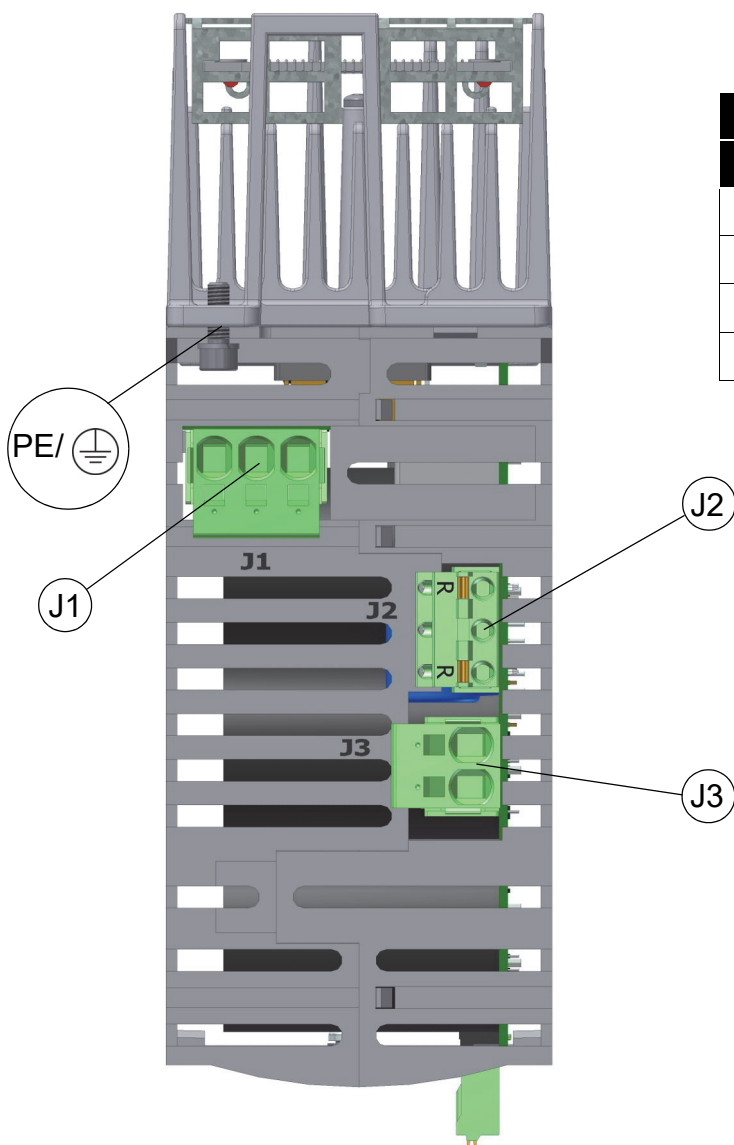

Connections	
Marking	Description
J1	Main supply
J2	Braking/discharge resistor
J3	DC BUS output
PE	Protective Earth/Ground

5.4.2 Front view

The following picture shows the connections available on the front face of the device:

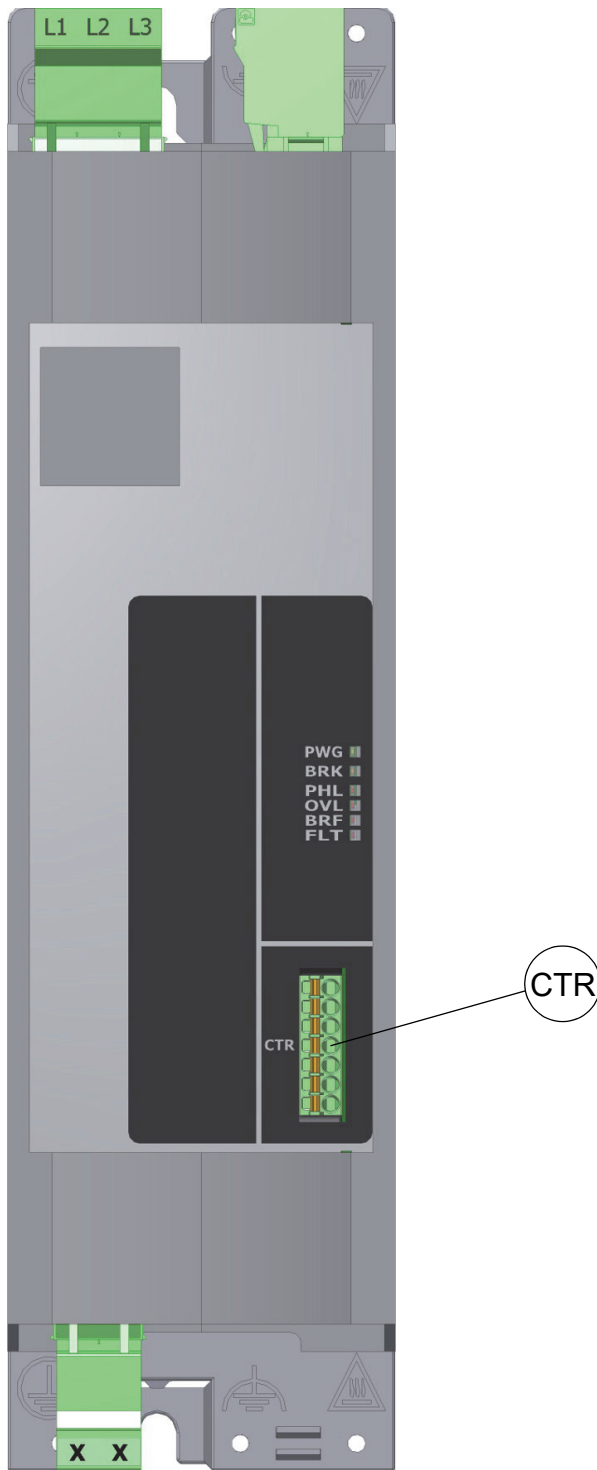

Connections	
Marker	Description
CTR	Auxiliary power and I/Os

5.4.3 Bottom view

The following picture shows the connections available on the bottom face of the device:

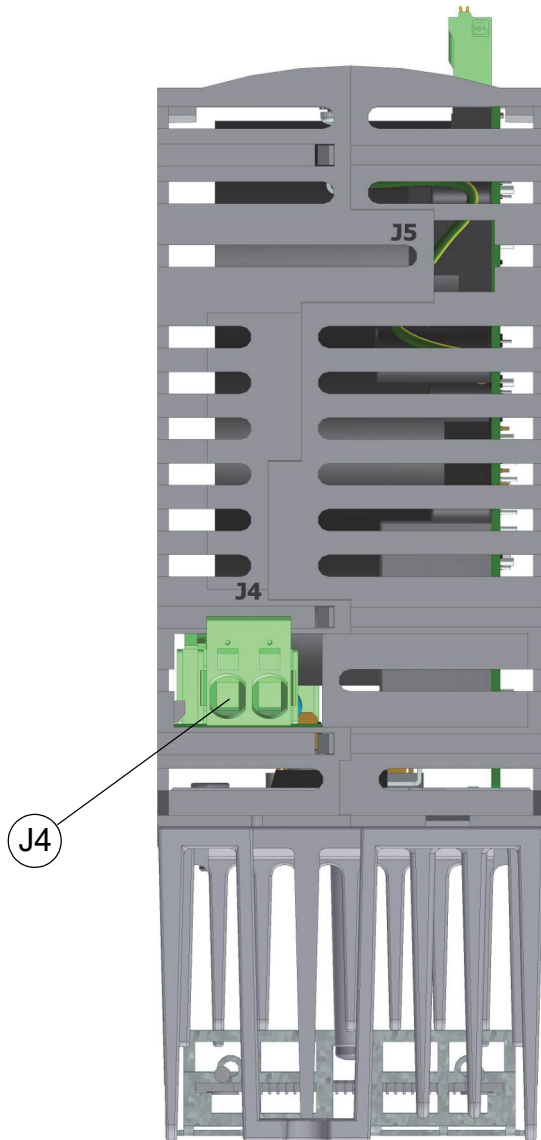

Connections	
Marker	Description
J4	Reactor (if not used, connect a jumper using 6 mm ² / 8 AWG wire.)

5.5 Mains power supply - J1

These are the connections to 230VAC mains power and line filter.

CAUTION



Large capacitors inside the device. Risk of Electric Shock; wait at least No. 600 seconds (10 minutes) after disconnecting power. Do not connect or disconnect cable and connectors before that time.

ATTENTION



Hautes capacités présentes à l'intérieur de l'appareil. Risque de choc électrique; attendez au moins 600 secondes (10 minutes) après la mise hors tension. Les câbles et les connecteurs ne doivent pas être connectés ou déconnectés avant la fin du temps indiqué.

The connections are possible through the detachable connector J1 (see picture). The connector pinout is indicated in the table:

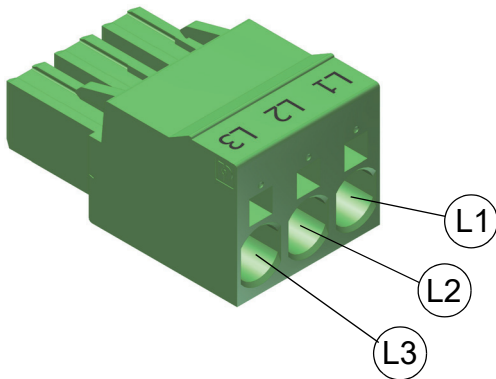

Power supply 230V	
Marker	Signal
L1	230VAC line - phase 1
L2	230VAC line - phase 2
L2	230VAC line - phase 3

Connector type: Phoenix Contact SPC 5/3-ST-7,62 (1996029)			
Order code: KF101042			
Features		Conductors cross section * **	
Connection in accordance with	EN-VDE	Solid min.	0,2 mm ²
Rated voltage	1000 V	Solid max.	10 mm ²
Rated current	41 A	Stranded min.	0,2 mm ²
		Stranded max.	6 mm ²
Insulating material	PA	Stranded, with ferrule without plastic sleeve min.	0,25 mm ²
Inflammability class according to UL 94	V0	Stranded, with ferrule without plastic sleeve max.	6 mm ²
Stripping length	15 mm	Stranded, with ferrule with plastic sleeve min.	0,25 mm ²
Screwdriver to be used for opening the connections	0,6 x 3,5 mm	Stranded, with ferrule with plastic sleeve max.	4 mm ²
		AWG according to UL / CUL min	24
		AWG according to UL / CUL max	8
		*= Use 60 °C / 75 °C wires only **= Use Copper Conductors only	

CAUTION

For safety reasons, the device must always operate with the PE (Ground) terminal connected, to avoid electrical shock. The PE (Ground) connection must be carried out by means of the specific terminal; do not rely on the mechanical fastening screws only.

The PE (Ground) protective conductor section must not be lower than 2.5 mm²/ 12 AWG, according to EN 61800-5-1 standard. Should the conductor be without mechanical protection, the section must be increased to 4 mm²/ 10 AWG.

ATTENTION

Pour des raisons de sécurité, l'appareil doit toujours fonctionner avec la connexion PE (Ground) insérée. risque d'électrocution! Le raccordement de PE (Ground) doit être effectué à l'aide de la vis appropriée, en évitant de compter uniquement sur les vis de fixation mécaniques.

La section du conducteur de protection PE (Ground), conformément à la norme EN 61800-5-1, ne doit pas être inférieure à 2,5 mm² / 12 AWG. Si ce conducteur ne dispose pas de protection mécanique, cette section doit avoir une taille minimale de 4 mm² / 10 AWG.

The following paragraphs describe in detail how to make connections.

5.5.1 Connection schematic

The recommended connection schematic is shown on the following page; these devices are designed to operate with TT or TN distribution networks.

For use in accordance with UL certification, only TN distribution is permitted.

The power supply unit can operate on both single-phase or three-phase networks. In case of single-phase, it is necessary to reduce the output current and set the device to single-phase mode by means of the jumper (see specific paragraph). If the device is set in the wrong way, the overload protection and the missing phase detection will not function correctly.

WARNING



A wrong setting of the device may cause overload, with consequent danger of fire and possible damage to people and things.

AVERTISSEMENT



Un réglage incorrect de l'appareil peut causer des dommages dus à une surcharge, à un risque d'incendie et à des dommages corporels ou matériels.

The device and the power conductors must be protected against overcurrents and short-circuits by a suitable protection device. Since the input current is strongly distorted by the rectifier, its value may be considerably higher than the output current; therefore the protection devices must be selected carefully.

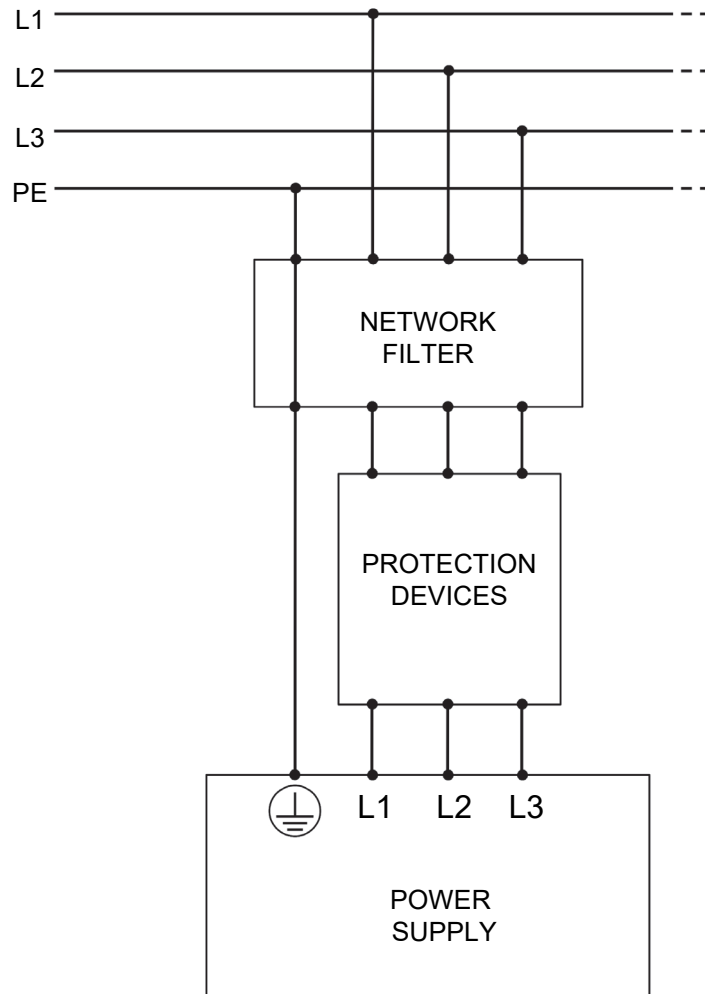

5.5.2 Conductors and protective devices

5.5.2.1 Protection for UL applications



This device is Suitable For Use On A Circuit Capable Of Delivering Not More Than 5000 Arms Symmetrical Amperes, 230Vac Maximum when protected by semiconductor fuse model FR14GR69V40T by Mersen.

5.5.2.2 Protection for other applications

The device and the power conductors can be protected by fuses or by automatic circuit breakers; the sizing of the conductors depends on the protection device type and its size.

The rated current of the protection device depends on the input current absorbed by the power supply unit; it cannot be determined in advance, because it strongly depends on the line impedance and on the inductance of an auxiliary reactor.

The tables here below indicate the recommended conductors and protective devices. We suppose that the input current is known and the cables are installed according to B1 method; for other methods of installation, refer to the EN IEC 60364-5-52 standard to calculate the current carrying capacity of the conductors.

The breaking capacity of the protective device must not be lower than the prospected short-circuit current at the point of installation.

In case of protection by means of fuses, it is recommended to use 10 x 38 mm class gG cartridge-type fuses.

The following table shows the recommended solutions:

Input current [ARMS a 40°C]	Fuse size [A]	Temperature [°C]	Conductor cross-section [mm ²]	
			PVC 70°C	EPR 90°C
I < 20	20	T < 40	4	2.5
		40 ≤ T < 55	6	4
20 ≤ I < 25	25	T < 40	6	4
		40 ≤ T < 55	10	4
25 ≤ I < 28	32	T < 40	10	6
		40 ≤ T < 55	16	6

In case of protection by means of automatic circuit breakers, it is recommended to use C-curve devices conform to EN IEC 60947-2 standard. The following table shows the recommended solutions:

Input current [ARMS a 40°C]	Fuse size [A]	Temperature [°C]	Conductor cross-section [mm ²]	
			PVC 70°C	EPR 90°C
I < 20	20	T < 40	4	2.5
		40 ≤ T < 55	6	2.5
20 ≤ I < 25	25	T < 40	4	2.5
		40 ≤ T < 55	10	4
25 ≤ I < 28	32	T < 40	6	4
		40 ≤ T < 55	10	6

5.5.3 EMI filtering

The power supply is designed to operate according to EN IEC 61800-3 standards (second environment, category C3). However, the emission levels strictly depends on the emissions generated by downstream devices. Since the servodrives are not equipped with EMI filter, it will be necessary to install an external EMI filter in order to comply with the emission levels required by the standards actually in force.

The selection process of the filter must take into consideration the following data:

- mains voltage;
- max input current;
- required insertion loss.

Unfortunately, it is not possible to size the filter in advance, because it depends on several factors, such as the number and type of downstream devices, the rules in force, the absorbed currents, etc...; therefore, it will have to be validated on the field, measuring the emission level.

CAUTION

The EMI filter gives rise to a considerable leakage current directed versus PE (Ground); don't energize the device without the PE (Ground) connection, in order to avoid the risk of Electric Shock when touching the exposed metal parts (such as the heatsink).

ATTENTION

Le filtre EMI génère un courant de fuite élevé vers PE (Ground); ne mettez pas l'appareil sous tension sans connecter PE (Ground) afin d'éviter tout risque de choc électrique en touchant des parties métalliques exposées (par exemple, le dissipateur de chaleur).

The power supply unit ICOS-PS 3160 has successfully passed the emission test with a load equal to 6 ICOS servodrives. For this test we used servodrives code EM700021 (ICOS 3210-FB 6 Nm 3000 rpm) and an EMI filter made by Schaffner (part-number FN3258H-30-33). It is therefore recommended to use this kind of filter:



Product category: line filter

Manufacturer: Schaffner

Kind of filter: 3-phase EMC/RFI ultra-compact

Nominal voltage: 480 VAC

Nominal current: 30 A

Mounting style: chassis

Termination style: terminal block

Leakage current: 33 mA

Approvals: UL, CSA, ENEC-14

Series: FN 3258

Working frequencies: DC to 60 Hz

Brand: Schaffner

These are the basic criteria for a correct installation of the device. If the user decides to install the device without following the recommendations stated before, he assumes the whole responsibility of checking that the following rules are satisfied:

- The cables used shall have a low RF impedance.
- The earth conductors must be adequately sized. To this purpose, it is necessary to install a second PE (Ground) conductor with a cross-section not inferior to that of the phase conductors (at least 4 mm²/ 10 AWG in this case). Alternatively, it is possible to use only one conductor, having a cross-section of at least 10 mm²/ 6 AWG (not less than that of the main conductor).
- The filter must be connected to earth PE (Ground).
- The conductors between filter and power supply unit ICOS-PS 3160 should be as short as possible.

5.6 Braking/discharge resistor output - J2

This connector allows the wiring of a power resistor for the dynamic braking and automatic discharge (ICOS-PS 3162 only); the following illustration shows the pinout of the connector (because it's a resistor, it is not necessary to observe the polarity):

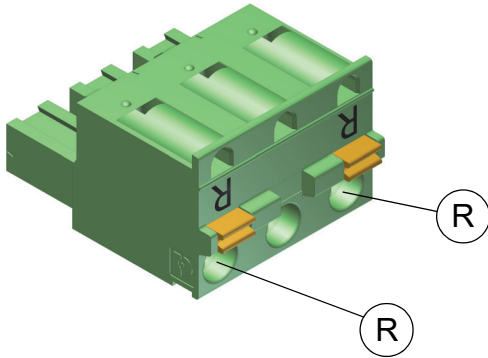

Braking resistor	
Marker	Signal
R	Resistor - 1
R	Resistor - 2

Connector type: Phoenix Contact GFKC 2,5/3-ST-7,62 (1939646)			
Order code: KF101043			
Features		Conductors cross section * **	
Connection in accordance with	EN-VDE	Solid min.	0,2 mm ²
Rated voltage	400 V	Solid max.	2,5 mm ²
Rated current	12 A	Stranded min.	0,2 mm ²
		Stranded max.	2,5 mm ²
Insulating material	PA	Stranded, with ferrule without plastic sleeve min.	0,25 mm ²
Inflammability class according to UL 94	V0	Stranded, with ferrule without plastic sleeve max.	2,5 mm ²
Stripping length	10 mm	Stranded, with ferrule with plastic sleeve min.	0,25 mm ²
Screwdriver to be used for opening the connections	0,6 x 3,5 mm	Stranded, with ferrule with plastic sleeve max.	2,5 mm ²
		AWG according to UL / CUL min	26
		AWG according to UL / CUL max	12
		* = Use 60 °C / 75 °C wires only ** = Use Copper Conductors only	

This function is sometimes necessary when you supply power to servodrives, which may create a flow of electric power directed versus the power supply unit during the motor braking phase. This often happens during cycles (cams) or during an emergency stop. During the braking, the energy coming from the load is stored in the bus capacitors, which increase their voltage. If a braking circuit is not available the voltage might increase uncontrollably, thus potentially damaging the devices, unless the servodrive (as usually happens) is disabled due to overvoltage. Such mode of operation causes a disappearance of the braking torque, not acceptable in most situations.

CAUTION



Large capacitors inside the device. Risk of Electric Shock; wait at least No. 600 seconds (10 minutes) after disconnecting power. Do not connect or disconnect cable and connectors before that time.

ATTENTION



Hautes capacités présentes à l'intérieur de l'appareil. Risque de choc électrique; attendez au moins 600 secondes (10 minutes) après la mise hors tension. Les câbles et les connecteurs ne doivent pas être connectés ou déconnectés avant la fin du temps indiqué.

To overcome this problem, it is necessary to dissipate the excess electric power, and this is obtained by inserting a braking resistor. It is energized by the power supply unit only in case of real need, and it avoids that the bus voltage reaches dangerous levels for the downstream devices and for the power supply unit itself. The braking resistor must be adequately sized according to the following factors:

- operating voltage (during the braking phase, it can reach 450V DC);
- average power: it must be higher than the average power generated during the braking phase;
- peak power: it must be higher than the peak power generated during the braking phase;
- cooling system: natural or forced ventilation, liquid cooling, etc...

The braking resistor can also be used to automatically discharge the internal capacities of the ICOS-PS 3162 power supplies; if in the application it is not necessary to perform dynamic braking but want to use the automatic capacity discharge function, it is possible to reduce the power of the resistor to be connected to this output taking into account that:

- the working voltage can reach 450V DC
- the recommended resistance value is between 20ohm and 60ohm; with low resistance values the discharge of capacitances is faster
- the adiabatic energy that the resistor must be able to withstand is at least 650J

CAUTION

	<p>In the event that no resistor is connected to this output, the power supply will not be able to perform dynamic braking or discharge the internal capacities!</p>
---	--

5.7 DC BUS output - J3

This connector delivers the output voltage generated by the power supply unit; the pinout is shown in the following image:

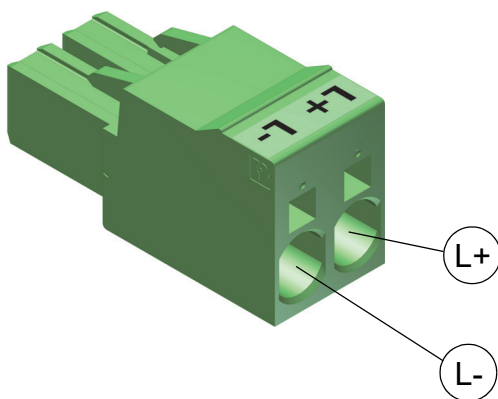

DC BUS output	
Marker	Signal
L+	DC BUS output - positive
L-	DC BUS output - negative

<p>Connector type: Phoenix Contact SPC 5/2-ST-7,62 (1996016)</p> <p>Order code: KF101078</p>			
Features		Conductors cross section * **	
Connection in accordance with	EN-VDE	Solid min.	0,2 mm ²
Rated voltage	1000 V	Solid max.	10 mm ²

Rated current	41 A	Stranded min.	0,2 mm ²
		Stranded max.	6 mm ²
Insulating material	PA	Stranded, with ferrule without plastic sleeve min.	0,25 mm ²
Inflammability class according to UL 94	V0	Stranded, with ferrule without plastic sleeve max.	6 mm ²
Stripping length	15 mm	Stranded, with ferrule with plastic sleeve min.	0,25 mm ²
Screwdriver to be used for opening the connections	0,6 x 3,5 mm	Stranded, with ferrule with plastic sleeve max.	4 mm ²
		AWG according to UL / CUL min	24
		AWG according to UL / CUL max	8
		*= Use 60 °C / 75 °C wires only **= Use Copper Conductors only	

The rectified voltage is not available immediately after powering up the device because it is necessary to wait for the charging of the capacitors, which starts after the reset signal assertion, turned high by the user and connected to the specific input. In order to reduce the inrush current and the stress on the electronic components, the initial charge phase is controlled by a series resistor inserted at the output of the rectifier bridge. When the charge is over, it is short-circuited by a power relay. Only after the relay contacts are closed, the user can drain current from the power supply unit, otherwise it would be damaged and the output voltage would not be stable. When the charge is over, the digital output POWER GOOD is asserted and the corresponding LED switches ON.

CAUTION

	<p>Large capacitors inside the device. Risk of Electric Shock; wait at least No. 600 seconds (10 minutes) after disconnecting power. Do not connect or disconnect cable and connectors before that time.</p>
---	--

ATTENTION

	<p>Hautes capacités présentes à l'intérieur de l'appareil. Risque de choc électrique; attendez au moins 600 secondes (10 minutes) après la mise hors tension. Les câbles et les connecteurs ne doivent pas être connectés ou déconnectés avant la fin du temps indiqué.</p>
---	---

	<p>Wait until POWER GOOD output is active (logic level "1") before starting to drain current from the output. Otherwise, the unit and the devices connected to it could be damaged.</p>
	<p>The output voltage is DC and is polarized. Be careful to the polarity when making the connections, otherwise you might damage the unit and the devices connected to it.</p>
	<p>If you need to disconnect and/or interrupt the continuous voltage downstream the device, use devices suited to operate with DC currents; otherwise, they might not be able to interrupt current, with consequent risk to people and devices.</p>

5.8 Auxiliary power and I/Os - CTR

This connector is used for the connection of digital I/Os, allowing the device to interface with an external system (eg. a PLC).

The following image shows the pin configuration:

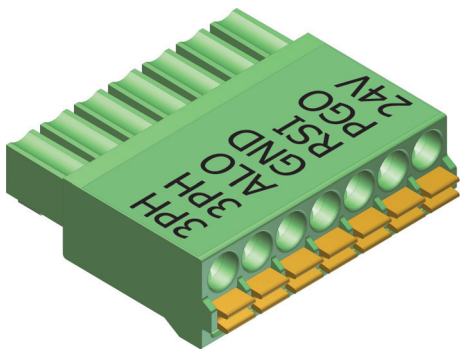

Power supply 230V	
Marker	Signal
3PH	1PH/3PH SETTING - jumper
3PH	1PH/3PH SETTING - jumper
ALO	ALARM - output
GND	GND
RSI	RESET - input
PGO	POWER GOOD - output
24V	24V - power supply

Connector type: Phoenix Contact FMC 1,5/7-ST-3,5 (1952319)			
Order code: KF101050			
Features		Conductors cross section * **	
Connection in accordance with	EN-VDE	Solid min.	0,2 mm ²
Rated voltage	160 V	Solid max.	1,5 mm ²
Rated current	8 A	Stranded min.	0,2 mm ²
		Stranded max.	1,5 mm ²
Insulating material	PA	Stranded, with ferrule without plastic sleeve min.	0,25 mm ²
Inflammability class according to UL 94	V0	Stranded, with ferrule without plastic sleeve max.	1,5 mm ²
Stripping length	10 mm	Stranded, with ferrule with plastic sleeve min.	0,25 mm ²
Screwdriver to be used for opening the connections	0,6 x 3,5 mm	Stranded, with ferrule with plastic sleeve max.	0,75 mm ²
		AWG according to UL / CUL min	24
		AWG according to UL / CUL max	16
		* = Use 60 °C / 75 °C wires only ** = Use Copper Conductors only	

5.8.1 Power supply setting

The device can operate either with single-phase or three-phase power supply. However, the deliverable output current strictly depends on the type of power supply (in single phase there is a considerable derating).

For a correct operation, it is necessary to set the type of power supply, by connecting or not a jumper between pin 1 and 2 of the CTR connector. The following table indicates the available statuses:

Jumper	Setting	Notes
Absent	Single-phase	Check of phase loss not active. Low current limit
Present	Three-phase	Check of phase loss active. High current limit

5.8.2 Interface I/Os

The power supply unit features a digital input (RESET) and two outputs (POWER GOOD and ALARM). They allow to interface the unit with external devices (such as a PLC). In this way, it is possible to know if the power supply unit is ready to operate and the user can reset some error conditions.

The following drawing shows how to make correct connections:

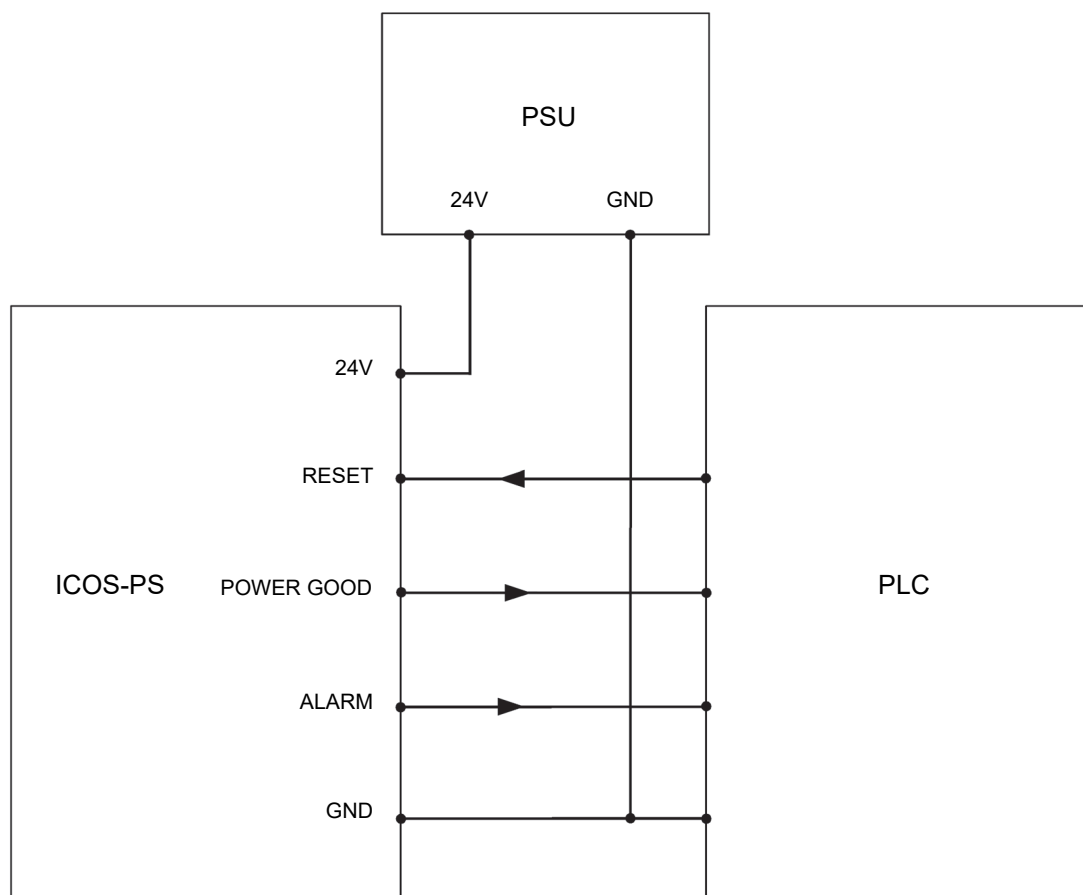

These inputs and outputs are suited for 24V digital signals, in order to be able to interface with standard industrial electronics (in particular PLCs).

The I/O functions are described in the following table:

Denomination	Types	Notes
RESET	Input	Input used for resetting possible error conditions. It includes the debouncing function to interface with electro-mechanical switches, if any; and it's "edge sensitive", which means that it becomes active only when the signal goes from low to high. This signal is active high.
POWER GOOD	Output	It indicates the status of the device.
ALARM	Output	It indicates if there is an alarm condition.
1PH/3PH SETTING	Input (Jumper)	It indicates to the unit if the power supply is single-phase or three-phase. If the jumper is present, it means that the device is set to operate with three-phase power supply; otherwise, with single-phase.

5.9 Reactor - J4

This connector serves to connect a reactor (optional) in series at the output of the rectifier bridge. Because the input current is highly distorted due to the non-linearity of the rectifiers, a large generation of current harmonics arise related to the current drawn from the mains. These cause some problems, such as:

- increase of the effective value of the input current, at the same active power delivered to the output;
- increase of the Joule losses on the power conductors;
- oversizing of the protective devices (magneto-thermal breakers, fuses) in order to face the increased request of current;
- problems due to maximum harmonics levels allowed by the rules in force;
- distortion of the mains power supply;
- overload of upstream transformers.

Distortion can be reduced by installing an adequately sized reactor in series with the rectifier bridge; to this purpose, a connector is available (see drawing):

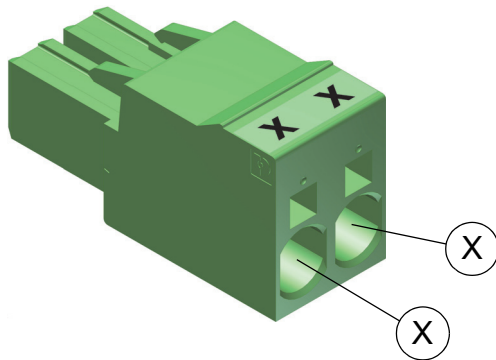

Reactor	
Marker	Signal
X	Reactor - 1
X	Reactor - 2

Connector type: Phoenix Contact SPC 5/2-ST-7,62 (1996016)			
Order code: KF101078			
Features		Conductors cross section * **	
Connection in accordance with	EN-VDE	Solid min.	0,2 mm ²
Rated voltage	1000 V	Solid max.	10 mm ²
Rated current	41 A	Stranded min.	0,2 mm ²
		Stranded max.	6 mm ²
Insulating material	PA	Stranded, with ferrule without plastic sleeve min.	0,25 mm ²
Inflammability class according to UL 94	V0	Stranded, with ferrule without plastic sleeve max.	6 mm ²
Stripping length	15 mm	Stranded, with ferrule with plastic sleeve min.	0,25 mm ²
Screwdriver to be used for opening the connections	0,6 x 3,5 mm	Stranded, with ferrule with plastic sleeve max.	4 mm ²
		AWG according to UL / CUL min	24
		AWG according to UL / CUL max	8
		*= Use 60 °C / 75 °C wires only **= Use Copper Conductors only	

It is not necessary to observe any polarity when connecting the reactor.

CAUTION

Large capacitors inside the device. Risk of Electric Shock; wait at least No. 600 seconds (10 minutes) after disconnecting power. Do not connect or disconnect cable and connectors before that time.

ATTENTION

Hautes capacités présentes à l'intérieur de l'appareil. Risque de choc électrique; attendez au moins 600 secondes (10 minutes) après la mise hors tension. Les câbles et les connecteurs ne doivent pas être connectés ou déconnectés avant la fin du temps indiqué.

The reactor must be adequately sized, in order to:

- can withstand the current RMS value without overheating;
- doesn't saturate when the current reaches its peak value (pls. see graphs).
- can withstand continuously the working voltage without interruptions; for the purpose of selection, suppose overvoltage category III.

The maximum length of the conductors used to wire the reactor must be less than 3 meters; they should be kept as far away as possible from signal carrying conductors in order to avoid interferences.



If the reactor is not used, put a jumper on connector J4, by using a 6 mm²/ 8 AWG wire.

The following graphs indicate the current magnitude as a function of the reactor inductance (the first chart refers to single-phase power supply, the second one to three-phase). The maximum inductance value must be equal to 500uH.

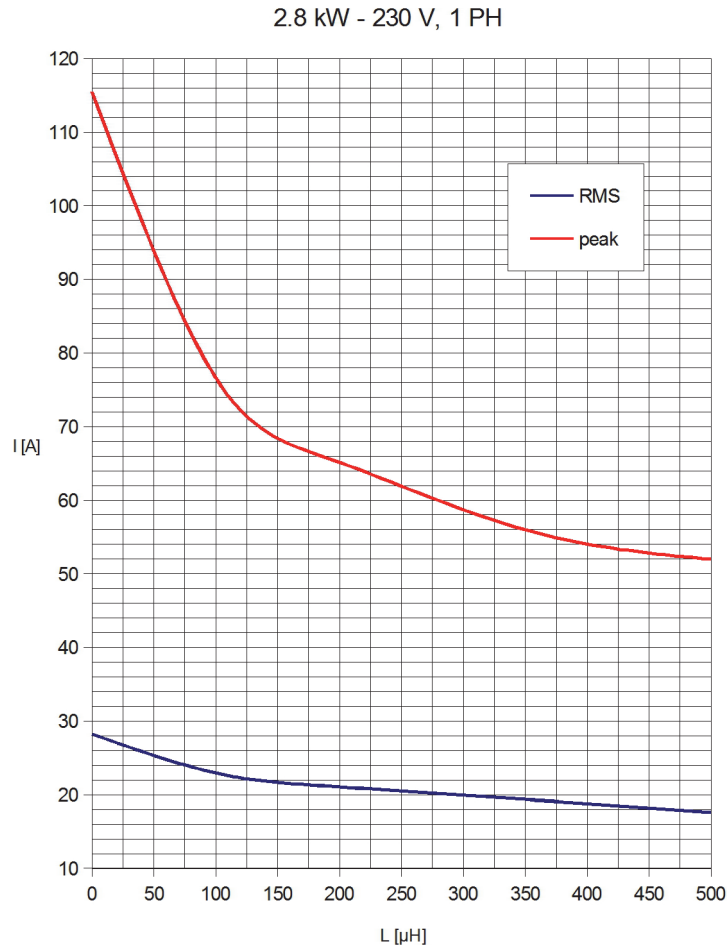

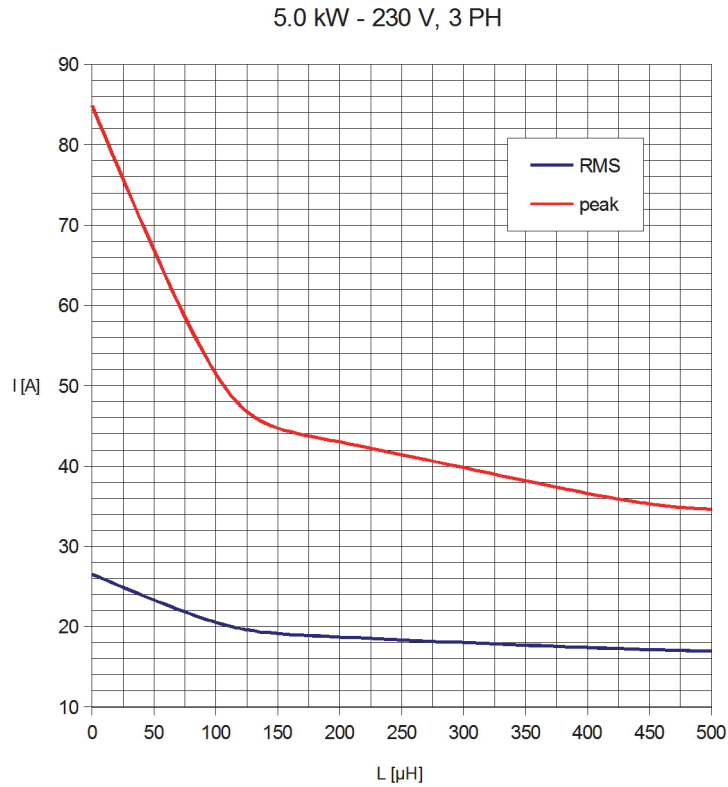

The insertion of a reactor causes a reduction of the output voltage as indicated in the two following graphs, showing the output voltage magnitude as a function of the reactor inductance, with the maximum permissible load pertinent to the type of power supply (the first graph refers to single-phase, the second one to three-phase). Lower absorptions cause lower voltage drops.

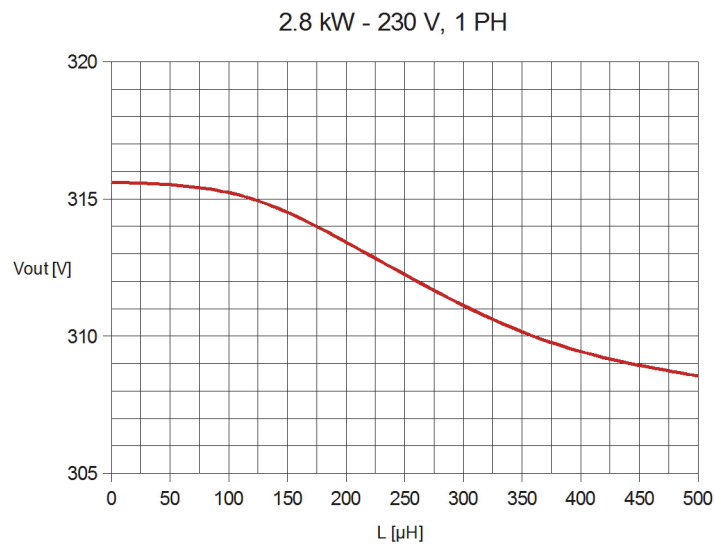

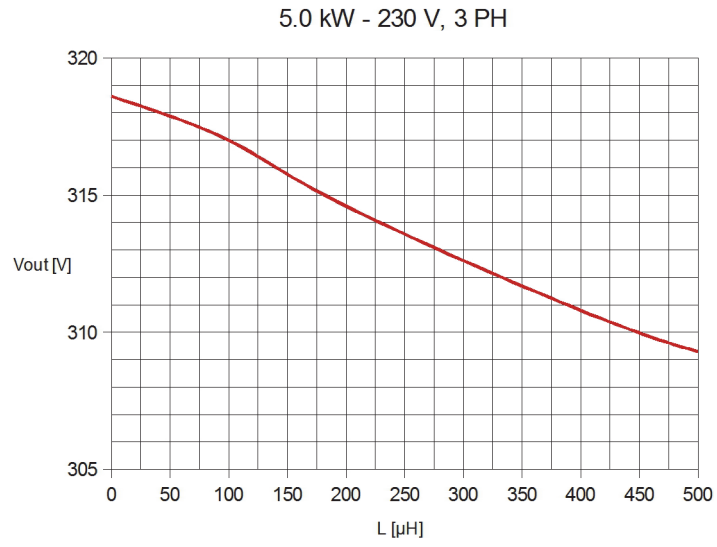

5.10 Status LEDs

The power supply unit features some LEDs on the front panel, indicating the status of the device and operation errors, if any. There are six LEDs; the following image shows their position:



The characteristics and function of each LED are summarized in the following table:

Denomination	Color	Function
PWG	Green	POWER GOOD: it indicates the status of the power supply unit. If this LED is flashing, it means that the device is pre-charging the bus capacitors or there are some anomalies and/or faults. If the LED is on and steady, it means that the pre-charging phase is over and the power supply unit is ready for operation.
BRK	Orange	BRAKING: it switches ON at the same time as the dynamic brake activation or automatic discharge of internal capacities (ICOS-PS 3162 only).
PHL	Red	PHASE LOSS: it switches ON when one of the three power supply phases is missing. It is always turned off if the device is set to single-phase operation.
OVL	Red	OVERLOAD: it switches ON during the pre-charge phase if the load is drawing current (not allowed) or when the power supply unit output is overloaded during normal operation.
BRF	Red	BRAKE FAULT: it switches ON in case of short-circuit of the braking/discharge resistor or in case of a resistor of too low ohmic value.

FLT	Red	CPU FAULT: it switches ON in case of CPU fault (device failure).
-----	-----	--

6 Operation and diagnostics

The power supply units are designed to rectify and stabilize the mains voltage (single-phase or three-phase), in order to deliver power to servodrives or other devices requiring a DC voltage.

ICOS-PS 3160 power supply units also manage the surplus of energy caused by the deceleration of the motors controlled by the servodrives; this energy is dissipated onto external resistors; this function is called “dynamic braking”.

Here are the main diagnostic functions of the ICOS-PS 3160 power supply units:

- detection of output overload;
- detection of the absence of one of the supply phases
- detection of undervoltage;
- detection and protection against short-circuit of the external brake resistor.

The control logic of the ICOS-PS 3160 power supply units is directly powered by the mains; it regulates the charge of the capacitors battery, detects overcharges, controls the dissipation of the energy surplus, and signals the operational status of the power supply unit itself, by means of specific digital outputs and LEDs.

For a better protection of the supply unit and for a more precise diagnosis of its statuses, it is recommended to interface the digital outputs to a PLC system which should control the drives supplied by the unit and turning them on and off at the right moment, also reading their status and their currents and voltages.

6.1 General status

The general status is indicated by LEDs FLT and PWG according to the following table.

Condition	PWG LED	FLT LED	Action
Not powered	Off	Off	Check the power supply
Faulty	Off	Off	Do not use the power supply unit
Faulty	Off/Lamp/on	Off	Do not use the power supply unit
Working	Lamp/on	Off	The power supply can be used

6.2 Capacitors charging

For the stabilization of the rectified line voltage, the power supply unit contains high-capacitance electrolytic capacitors, initially discharged. The initial charging must be adequately controlled, in order to prevent the mains from absorbing a large peak of current (inrush current), which might cause the following inconveniences:

- high stress on the electronic components (diode bridge, capacitors);
- intervention of upstream protection devices;
- voltage drops which might affect other devices.

This phase, called “charging”, is started by the power supply unit when it receives a digital signal on the RESET input, while the power supply is ON.

The charging phase is also repeated after the first start, whenever a diagnostic alarm disables the power supply unit output; also in this case, the charging phase is started after a signal on the RESET input.

While waiting for the RESET signal and during the charging phase, the PWG LED is flashing.



Before the charging phase is completed, it is not possible to apply any load to the power supply unit output, otherwise the power supply unit would be damaged.

When the charging phase is completed, the power supply unit is ready and the PWG LED will be ON and steady; the PWG digital output will be activated.

Here is a summary table:

Condition	PWG LED	PWG output	Meaning
Start or alarm	Lamp	0	Waiting for the RESET signal
RESET 0 → 1	Lamp	0	Charging phase
Full charge	On	1	Power supply unit ready

6.3 Anomalies during the charging phase

In some cases, the charging phase may not be completed and the power supply unit enters the alarm status, waiting for the RESET signal in order to be restored and start a new charging phase.

Here are the cases when the power supply unit may enter the alarm status during the charging phase:

- input supply voltage > 310VAC;
- output current > 1A;
- power supply missing phase;
- faulty charging circuit of the power supply unit.

A successful charging phase takes no more than 5s after the impulse on the RESET input; if it is not successful due to one of the above mentioned causes, the PWG LED and the PWG digital output will remain OFF.

In this case, the diagnosis of the problem causing the alarm must also take into consideration the information coming from the servodrivers connected to the power supply unit, according to the following table:

Condition	PWG LED	PHL LED	OVL LED	PWG output	ALARM output	Servo drivers	Meaning
Input supply voltage >310VAC	Lamp	Off	Off	0	0	Voltage >435VDC within 5s from the start	Excessive supply voltage. NOTE: Disconnect the power supply, in order to reduce the risk of damaging the power supply unit.
Output current >1A	Lamp	Off	On	0	1		Load already active or faulty; output short-circuit. NOTE: disable the load, in order to reduce the risk of damaging the power supply unit. Wait for the reset signal.

Power supply missing phase	Lamp	On	Off	0	0	Voltage >250VDC within 5s from the start	One of the three phases of power supply is missing or the power supply unit has not been set to single-phase operation. Wait for the reset signal.
The charge phase takes longer than 5s	Lamp	On	Off	0	0	Voltage <250VDC after 5s from the start	Faulty charging circuit of the power supply unit. Wait for the reset signal.

6.4 Working operation and possible anomalies

When the capacitors charging phase is over, the power supply unit activates the PWG digital output and the PWG LED is turned ON, indicating that the power supply unit is ready; from this moment, the load can be activated and can remain in this status as long as the PWG digital output remains active.



If the PWG signal turns off, it means that there is an alarm and the load must be disconnected, in order to reduce the risk of damaging the power supply unit.

Here are the causes due to which the power supply unit may enter the alarm status during the operational phase:

- input supply voltage < 120VAC
- output overload (concerning single-phase or three-phase power supply)
- power supply missing phase
- short-circuit of the dynamic brake resistor

In these cases, the diagnosis of the problem causing the alarm must also take into consideration the information coming from the servodrives connected to the power supply unit, according to the following table.

Condition	PWG LED	PHL LED	OVL LED	BRF LED	PWG output	ALARM output	Servo drivers	Meaning
Input supply voltage <120VAC	Lamp	Off	Off	Off	0	0	Voltage <170VDC	Supply voltage too low (line voltage drop, broken fuse, circuit-breakers opening). Wait for the reset signal.
Output overload (see tripping curves)	Lamp	Off	On	Off	0	1	Voltage >250VDC	Output overload. NOTE: disconnect the load in order to reduce the risk of damaging the power supply unit. Wait for the reset signal.
Power supply missing phase	Lamp	On	Off	Off	0	0	Voltage >250VDC	One of the three phases of power supply is missing or the power supply unit has not been set to single-phase operation. Wait for the reset signal.

<p>Dynamic braking resistor short-circuit</p>	<p>On</p>	<p>Off</p>	<p>Off</p>	<p>On</p>	<p>1</p>	<p>1</p>	<p>Voltage >250VDC</p>	<p>Short-circuit on the dynamic braking resistor output. The power supply unit continues working, but can not dissipate the excess energy. Wait for the reset signal.</p> <p>NOTE: resetting the power supply unit without solving the short-circuit may damage the power supply unit.</p> <p>NOTE: In case of alarm due to missing phase or overload, this alarm will take priority over the status of PWG and ALARM outputs.</p>
<p>Output voltage >450VD</p>	<p>On</p>	<p>Off</p>	<p>Off</p>	<p>Off</p>	<p>1</p>	<p>0</p>	<p>Voltage >450VDC</p>	<p>The power supply unit can not dissipate the excess energy on the dynamic braking resistor (the resistor is disconnected, faulty or undersized; excess of energy can not be managed by the power supply unit).</p> <p>NOTE: disconnect the load in order to reduce the risk of damaging the power supply unit.</p>

The maximum currents that are continuously available at the output are indicated in the following table:

Power supply	Current
Single-phase	9.0A
Three-phase	16.0A

The following chart indicates the maximum time during which a certain current limit can be exceeded, without overload error message. It refers to three-phase power supply.

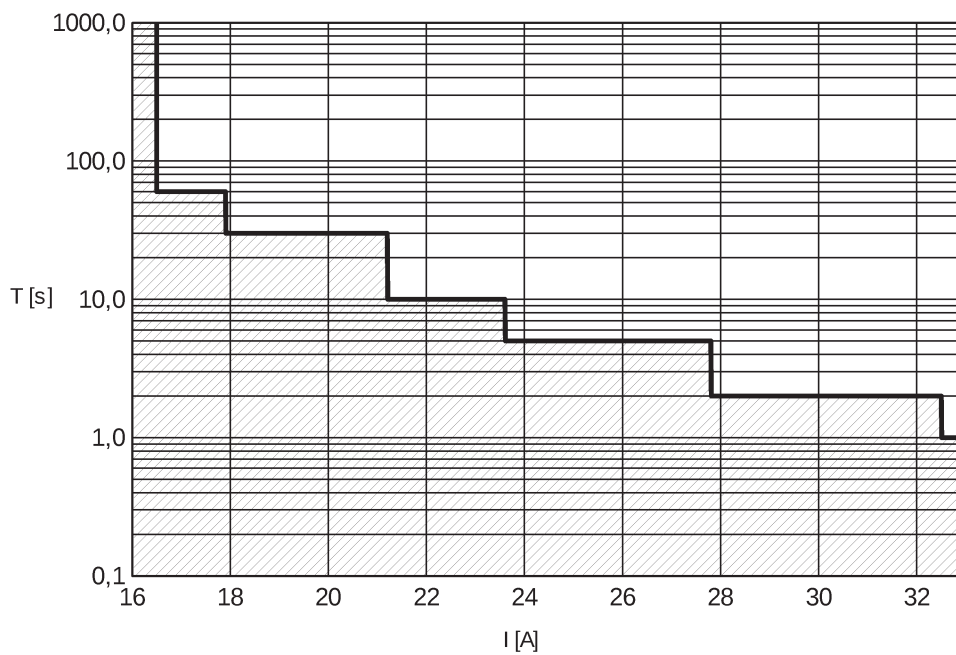

The following chart refers to single-phase power supply:

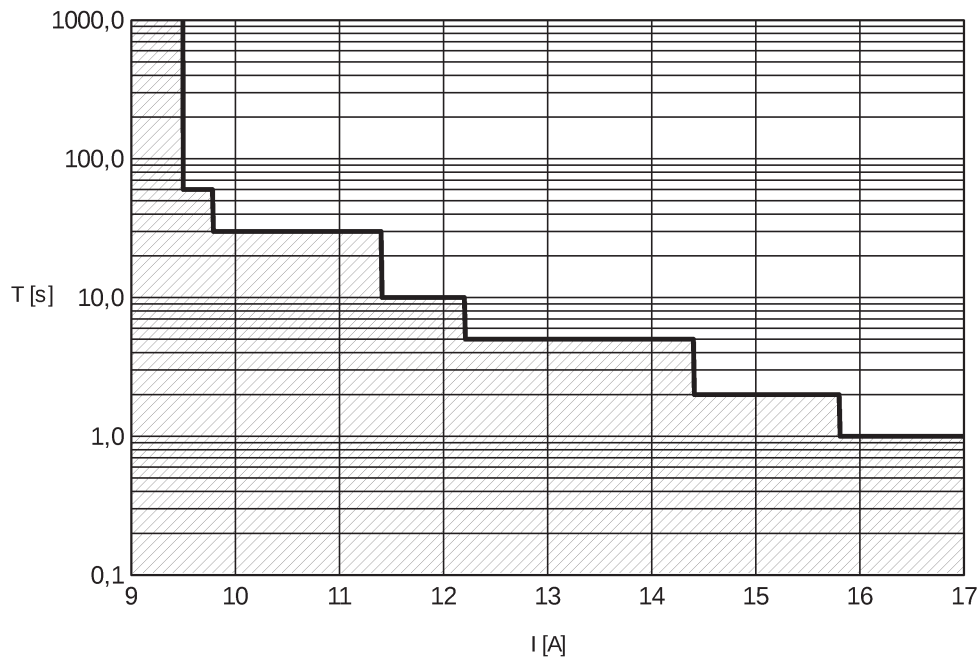

The curves refer to gPV 10x38 fuse-links. More precisely, the overload diagnostic intervenes earlier than the fuse, provided the rated current of the fuses in use is equal to 12A (single-phase) and 20A (three-phase). The fuse blows only in case of short-circuit or heavy overload, thus avoiding its interruption during normal operation.

The use of fuses with a different tripping curve may not ensure that they don't blow: the fuse might broke down in case of overload. If you want to use different fuses, their intervention time should be greater than that of the power supply unit for all range of expected overload currents (please adopt a proper safety factor, due to the variability of the fuses characteristics).

6.5 Dynamic braking

The dynamic braking circuit dissipates the energy coming from the load and directed to the power supply unit, as it usually occurs with servodrives.

More in detail, during the motor braking phase, the mechanical energy due to the slowdown of inertial loads is converted to electrical energy. Since this energy can not be conveyed to the mains, it is stored in bus capacitors, thus increasing their voltage. In absence of a braking system, the bus voltage might increase in an uncontrolled way, thus potentially damaging the devices unless the servodrive is disabled due to overvoltage. However, this condition is unacceptable, because the motor braking torque would be absent.

In order to avoid this problem, the dynamic braking stage dissipates this energy in a power resistor (external to the power supply unit and properly sized). It is connected to the bus voltage using an IGBT transistor, which is activated only when the bus exceeds a preset threshold. It is disabled when the bus voltage decreases below the threshold, thus avoiding unnecessary dissipation of power.

Depending on the resistor value and on the braking power, the bus voltage might anyway increase up to dangerous levels; in this case, the power supply unit is protected by downstream devices: the ICOS 320X servodrivers are suited for this purpose.

The activation of the dynamic brake output is signalled by the BRK LED. Paragraph 6.4 describes the anomalies that might affect the dynamic braking system.

6.6 Missing phase

Feeding the equipment with a three-phase power line, it might occur that a phase is missing (for example, due to the interruption of a protection fuse). In this case, the RMS input current on the remaining phases would increase considerably and might damage the power supply unit.

In order to avoid this problem, a dedicated circuit immediately detects if a phase is missing. This control is active only in case the power supply unit is set for three-phase operation. If the phase absence is longer than 5 seconds, the power supply unit enters the alarm status.

See paragraphs 6.3 and 6.4 for the signal modes.

6.7 Automatic capacity discharge operation (ICOS-PS 3162 only)

In some cases it is useful that when the main power supply is interrupted, for example when this is disconnected by safety switches, the energy still present inside the power supply is quickly eliminated in order to prevent the devices connected downstream from it. they can use to make unwanted movements.

This can be done by burning this energy on a resistor specifically connected to the dynamic brake output or on the same resistor used for dynamic braking.

The automatic discharge is activated 100ms from the disconnection of the main power supply; should the power supply voltage return during the discharge phase, the latter would be immediately interrupted, returning the power supply to its normal operating state.

The discharge time varies according to the DC Bus voltage present inside the power supply and the discharge/braking resistor value connected to the dynamic brake output.

For reference, keep in mind that the DC Bus voltage to reduce from 450VDC to 60VDC overall takes approximately:

- 400ms with 20ohm resistor
- 550ms with 30ohm resistor
- 650ms with 40ohm resistor
- 780ms with 50ohm resistor
- 900ms with 60ohm resistor

ATTENTION



The ICOS-PS 3160 power supply is not certified to perform safety functions such as STO; if certified safety functions are required, it is necessary to provide specially designed external devices

6.8 Digital input: RESET

It is possible, in the situations listed before, to cancel an alarm status. The signal must be kept to logic level "1" for at least 100 ms (see picture here below) and there is a debouncing software routine suited for signals coming from electro-magnetic switches.

The resetting procedure is non effectively performed if the output current is higher than 1A, in order to avoid the risk of damaging the power supply unit.

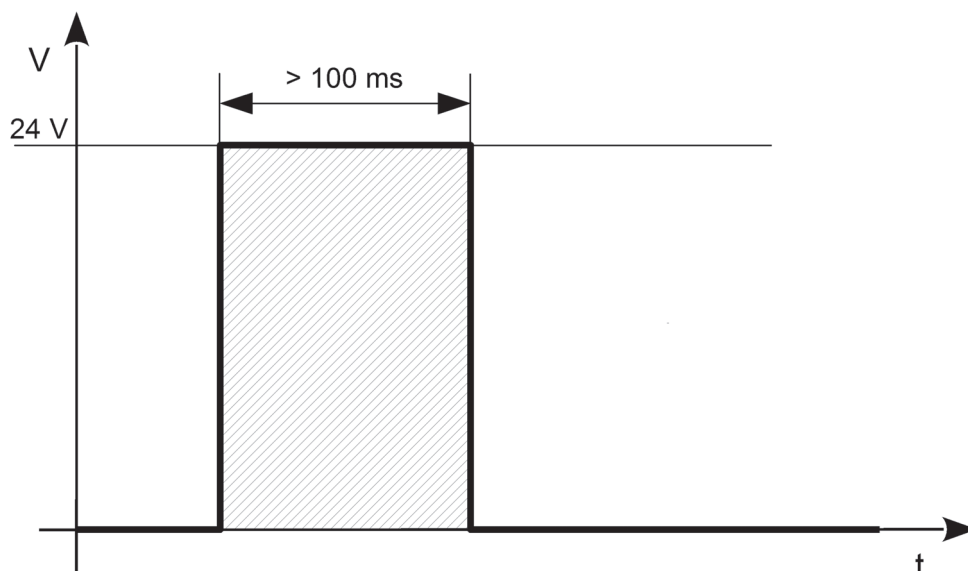

7 Storage

The power supply unit and its components can be stored in their original packaging and always in a covered place, even if they are packed. Protect the device against dust and atmospheric agents.

Do not stack more than 10 power supply units, in order to avoid overstressing of the package and/or the device.

The storage temperature should be within -25° and $+55^{\circ}\text{C}$.

8 Maintenance

WARNING



Large capacitors inside the device. Risk of Electric Shock; wait at least No. 600 seconds (10 minutes) after disconnecting power. Do not connect or disconnect cable and connectors before that time.

ATTENTION



Hautes capacités présentes à l'intérieur de l'appareil. Risque de choc électrique; attendez au moins 600 secondes (10 minutes) après la mise hors tension. Les câbles et les connecteurs ne doivent pas être connectés ou déconnectés avant la fin du temps indiqué.

8.1 Replacement of the charging resistor

In case of failure of the charging resistor, replace it as indicated in the following image (the component KG020098 must be ordered as a spare part).

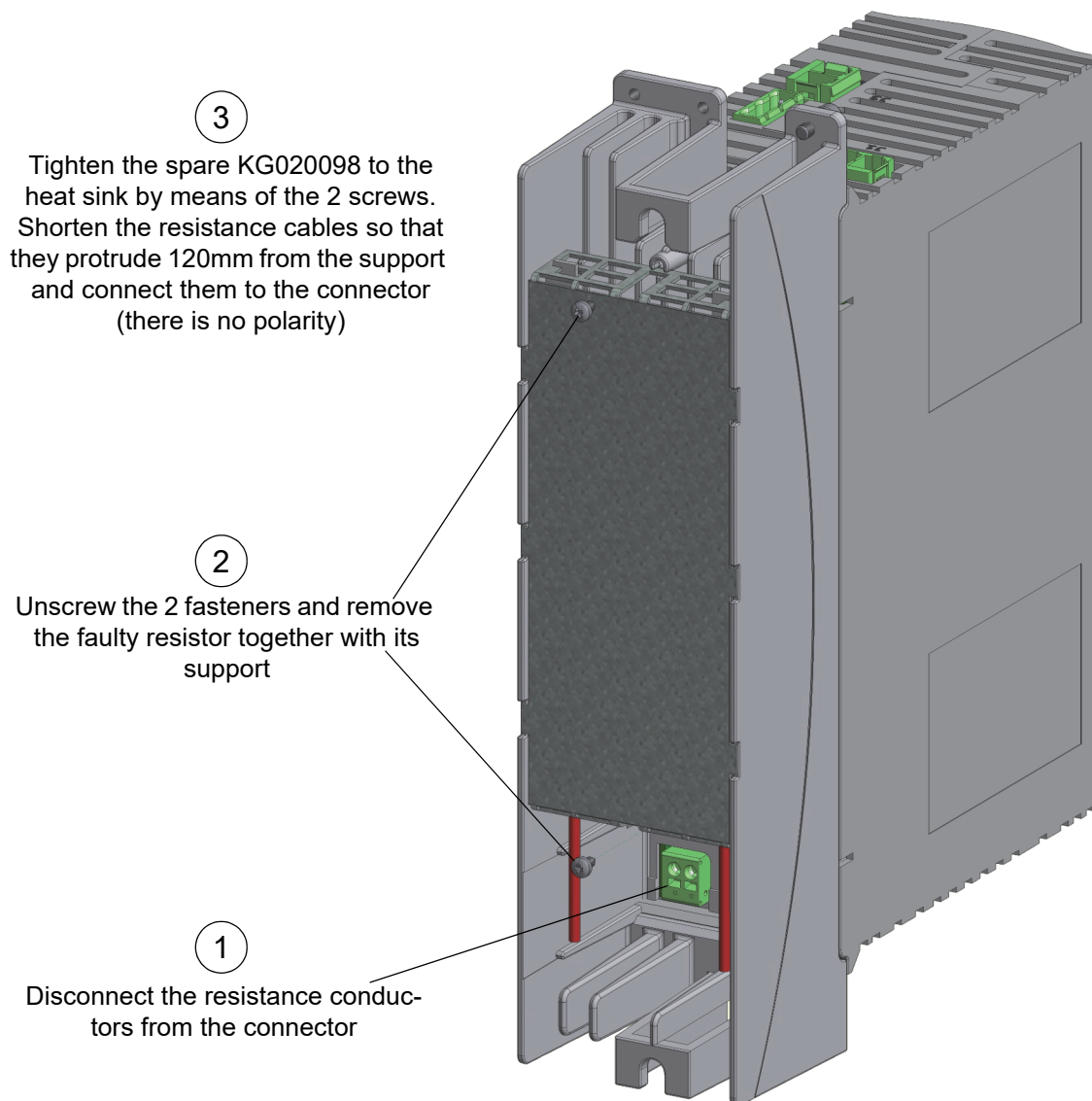

9 Decommissioning and disposal

The disposal of this device must be carried out according to the laws in force in the country where it was installed. Should the disposal be partial (frame, heat sink, electronic boards), separate the components made of plastic from the components made of aluminium, etc. Their disposal must be in compliance with the law in force in the country where the device was installed.

10 Analytical index

Numerics

1PH/3PH	12, 34, 37
24V	34

A

Alarm	12, 34, 36, 37, 48, 50
Altitude	10
Anomalies	48, 49
Assembly	7
Auxiliary mains	11
Auxiliary power	34

B

Brake resistor	12
Braking resistor	18, 29
BRF	44, 50
BRK	44

C

Capacitors charging	47
Charging phase	48
Charging resistor	12, 58
Conductors	26
Connection schematic	24
CTR	8, 19, 34

D

Danger	5
DC BUS	18, 31
DC output	11
Degree of protection	10
Derating	10
Diagnostics	46
Digital input	55
Dynamic brake output	11
Dynamic braking	53

E

Electrical shock	5
Electrocution	8
Electromagnetic field	9
EMI filtering	27
EN IEC 60364-5-52	26
EN IEC 61800-3	27
EN 61800-5-1	16
Environment of use	10

F

Fastening	16
Filter	28
FLT	45

G

General status	46
Ground	8, 18, 28

H

Handling	7
Heatsink	8

I

I/O	12, 34, 36
Individual protections	6

J

J1	18
J2	18, 29
J3	18, 31
J4	20, 38
Jumper	34

M

Mains supply	18, 21
Mains voltage	11
Max output current	11
Max output power	11
Missing phase	54

O

Operating temperature	10
Operation	46
OVL	44, 48, 50

P

PE	18
PHL	44, 48, 50
Positioning	14
Power good	12, 33, 34, 36, 37
Power supply	11, 21
Preliminary operations	14
Protective earth	18
PWG	44, 48, 50

R

Rated voltage	11
Reactor	12, 20, 38
Reset	12, 34, 36, 37, 55

S

Service	14
Short-circuit	11
Single-phase	35, 52
Status LEDs	44

T

Temperature 27
Three-phase..... 35, 52
TN distribution..... 24

W

Working operation..... 49