

Smitec S.p.A., via Carlo Ceresa 10, 24015 San Giovanni Bianco (BG), Italy, www.smitec.it



Installation, use and maintenance manual



BEFORE STARTING UP THE POSYC 3303 INDUSTRIAL PC, CAREFULLY READ THIS MANUAL AND FOLLOW ALL INSTRUCTIONS, IN ORDER TO ENSURE MAXIMUM SAFETY

INDUSTRIAL COMPUTERS

POSYC 3303



The technical data and the drawings in this manual might have been modified later; always refer to the latest version.

Summary

1 Preface	3
2 General warnings	4
3 Safety instructions	6
3.1 General information	6
3.2 Precautions during handling and assembly	6
4 Product description	7
4.1 Front view	8
5 Technical data	9
5.1 Environmental specifications	9
5.2 Electrical specifications	9
5.3 Mechanical specifications	10
5.3.1 Front view	10
5.3.2 Side view	11
5.3.3 Rear view (recommended panel cut)	12
5.4 Hardware features	13
5.4.1 Basic Hardware	13
5.5 Order codes	14
5.6 Accessories	14
6 Connections and LEDs	15
6.1 Connections side view	15
6.2 24V IN supply connector	17
6.3 RS485 serial port - COM1	19
6.4 Ethernet connectors	20
6.4.1 LED behavior for signaling of communication speed	20
6.4.2 LED behavior for signaling connection and communication activities	20
6.5 CFast card connectors	21
6.6 Battery slot	21
7 Installation	22
7.1 Panel assembly	22
7.2 Environmental requirements	23
7.3 Electrical wiring	23
7.3.1 RS485 serial port wiring	23
7.3.2 Serial signals RS485 port	25
8 Device use	26
8.1 Touch screen	26
8.2 CFast card	26
8.3 Priority of the start-up devices	27
8.4 Power ON	27
9 Ordinary maintenance	28
9.1 Cleaning the touch screen sensor	28
9.2 Clock battery replacement	28
9.3 CFast replacement	29
9.4 BIOS update	30
10 Appendices	31
10.1 Appendix I: CMOS Setup parameters	31
10.2 Appendix II: OS update and/or software installation	31
11 Analytical index	32

1 Preface

This manual provides all necessary information for the installation, use and maintenance of POSYC 3303 industrial PC.

The instructions included in this manual are addressed to the following professionals:

User	User is a person, a company or an institution that buys the equipment and uses it for the purposes it was designed for.
User/operator	User or operator is a person authorized by the user to operate on the equipment.
Specialized personnel	It refers to all persons with specific competence, able to recognize and avoid the dangers deriving from the use of the equipment.

The present instructions must be made available to all the above individuals.





2 General warnings

These assembly instructions are an integral part of the equipment, and must be kept for future reference until decommissioning.

The user should be informed that the present instructions reflect the state of the art at the moment when the equipment was sold; they will remain fully acceptable despite subsequent upgrades based on new experiences.

	<p>DO NOT USE THE EQUIPMENT, NOR MAKE ANY INTERVENTION BEFORE INTEGRALLY READING AND UNDERSTANDING THIS MANUAL.</p>
<p>IN PARTICULAR, ADOPT ALL SAFETY PRECAUTIONS AND PRESCRIPTIONS INDICATED IN THIS MANUAL.</p>	
<p>THE EQUIPMENT CANNOT BE USED FOR PURPOSES DIFFERENT THAN THE ONES DESCRIBED IN THIS MANUAL; SMITEC S.p.A. SHALL NOT BE HELD RESPONSIBLE FOR ANY DAMAGES, INCONVENIENCES OR ACCIDENTS DUE TO THE NON-COMPLIANCE WITH THESE PRESCRIPTIONS.</p>	

In order to make the manual consultation easier, the following symbols have been adopted:

	<p>Indication of "PROHIBITED ACTION".</p>
	<p>The symbol "DANGER" is used when the non-respect of the prescriptions or the tampering of organs can cause serious harm to people or things.</p>
	<p>The symbol "USE OF INDIVIDUAL PROTECTIONS" means that protective gloves must be worn.</p>
	<p>Indication of "INFORMATION OF PARTICULAR RELEVANCE".</p>



The safety prescriptions aim at establishing a series of behaviors and obligations to be complied with, while

performing the activities described later on in this manual.



These prescriptions constitute the prescribed method of operating the device, in a way that is safe for personnel, equipments and environment.

3 Safety instructions

3.1 General information

	<p>Do not install or use the equipment before integrally reading and understanding this manual. In case of difficulties of interpretation, contact SMITEC technical service.</p> <p>It is absolutely forbidden to use the equipment for different purposes than the ones described in this manual. The technical data and the drawings in this manual might have been modified later; always refer to the latest version. All upgrades can be requested to SMITEC S.p.A. directly.</p>
	<p>Make sure that the personnel is qualified and adequately informed about the risks he may run and how to avoid them.</p>
	<p>POSYC 3303 industrial PC can be used only after the classification of the machine operating area and after checking the safety levels, which must correspond to the assembly safety levels.</p>

3.2 Precautions during handling and assembly

	<p>Use adequate tools during the assembly, in order to avoid crushing or abrasions.</p>
	<p>Metal components and sharp surfaces may cause cuts and tears. In case of contact, be very careful and wear the personal protection equipment.</p>

4 Product description

The POSYC is a personal computer based on Intel® 64 hardware designed primarily to facilitate human-machine interfacing (HMI) in an industrial environment, but its characteristics make it suitable also for different uses, such as information terminals and automation systems in general.

The user interface has a flat color display with a 7 “diagonal LED illuminated and a touch screen pointing system integrated into the product.

The touch screen system offers features of robustness and ease of use, difficult to obtain with other common pointing devices such as mouse, track-ball and mouse pad.

Being completely integrated into the appliance, it is particularly suitable even in industrial applications that require resistance to external agents such as dust, humidity, water, oils, etc., which would be harmful for standard devices.

Since it is sufficient to exert a slight pressure with a finger on its surface to make an immediate pointing, this system is the main “User Friendly” feature of the POSYC computer.

In order to meet the most different interfacing needs, POSYC nevertheless provides the possibility to connect also standard input / output devices, such as keyboard, mouse, track-ball, monitor, etc.

In its minimum configuration, the POSYC can communicate with the external world via 1 standard RS485 serial port; it also offers 4 standard USB 3.0 ports, 2 10/100 / 1000Mb Ethernet ports, 1 HDMI port, 1 DP port.

The POSYC calculation capability is given by the Intel® Celeron® N3160 1.60GHz Quad Core processor with 4GB RAM.

The storage of data and programs on non-volatile support is entrusted to a 32GB CFast Card (high-speed flash memory). The position of the device inside the POSYC, is such as to allow its extraction without opening it. The main advantage of CFast Card is its exceptional resistance to accidental shocks and vibrations.

Its design makes it particularly attractive even for non-industrial applications.

4.1 Front view



5 Technical data

	<p>All the technical data in this section correspond to the hardware configuration of the POSYC 321X manufactured on the date when this manual was drawn up. To improve or update this product, SMITEC S.p.A. reserves the right to modify its technical features without notice.</p>
---	---

5.1 Environmental specifications

Operating temperature	0° ÷ +50°C when it is operating
Storage temperature	-20° ÷ +60°C when it is not operating
Relative humidity	0 ÷ 90% (without condensation)
Protection degree	IP65 on the front (according to IEC 60529 and type 1 UL) IP20 on the back (according to IEC 60529)
Maximum altitude	2000 m a.s.l.

5.2 Electrical specifications

The specifications below refer to the POSYC 321X unit alone, without any peripheral unit connected.

Mains voltage	24 VDC (-15% ÷ + 20% according to EN 61131-2) from CLASS 2 power supply (UL)
Absorbed current	Max 0.80A @ 24VDC
Absorbed power	Max 19.20W

5.3 Mechanical specifications

Fastening	Front panel with 4 through holes of 3.2 mm
Weight	1.28 kg

5.3.1 Front view

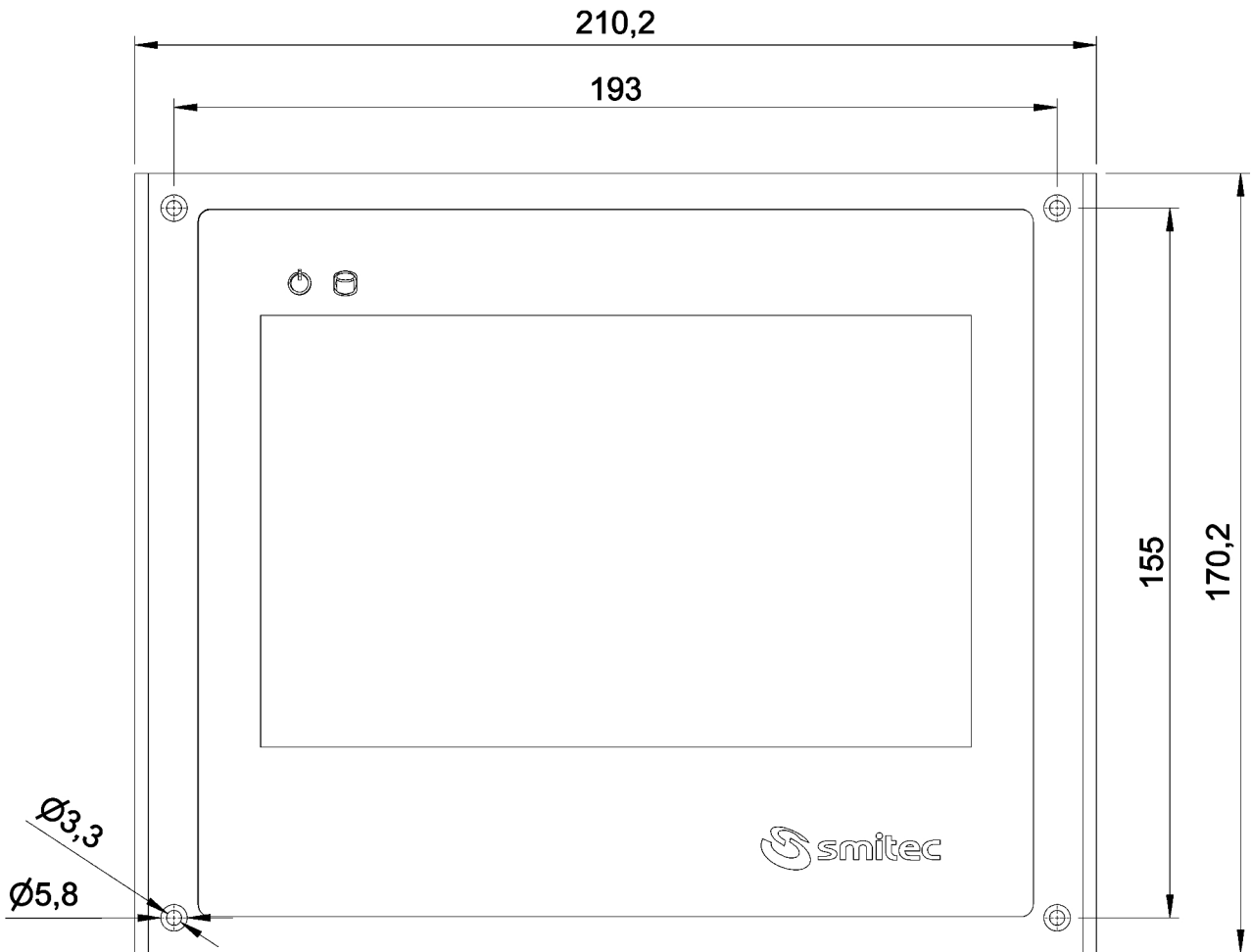

The computers Posyc 3303 need to be fixed on a stable and rigid panel provided with 4xM3 metal threaded hole, min. 1.5mm deep. Use 4xM3x10mm Fe/Zn (not countersunk head type) screws, min. class 8.8, tightened at 1Nm.

5.3.2 Side view

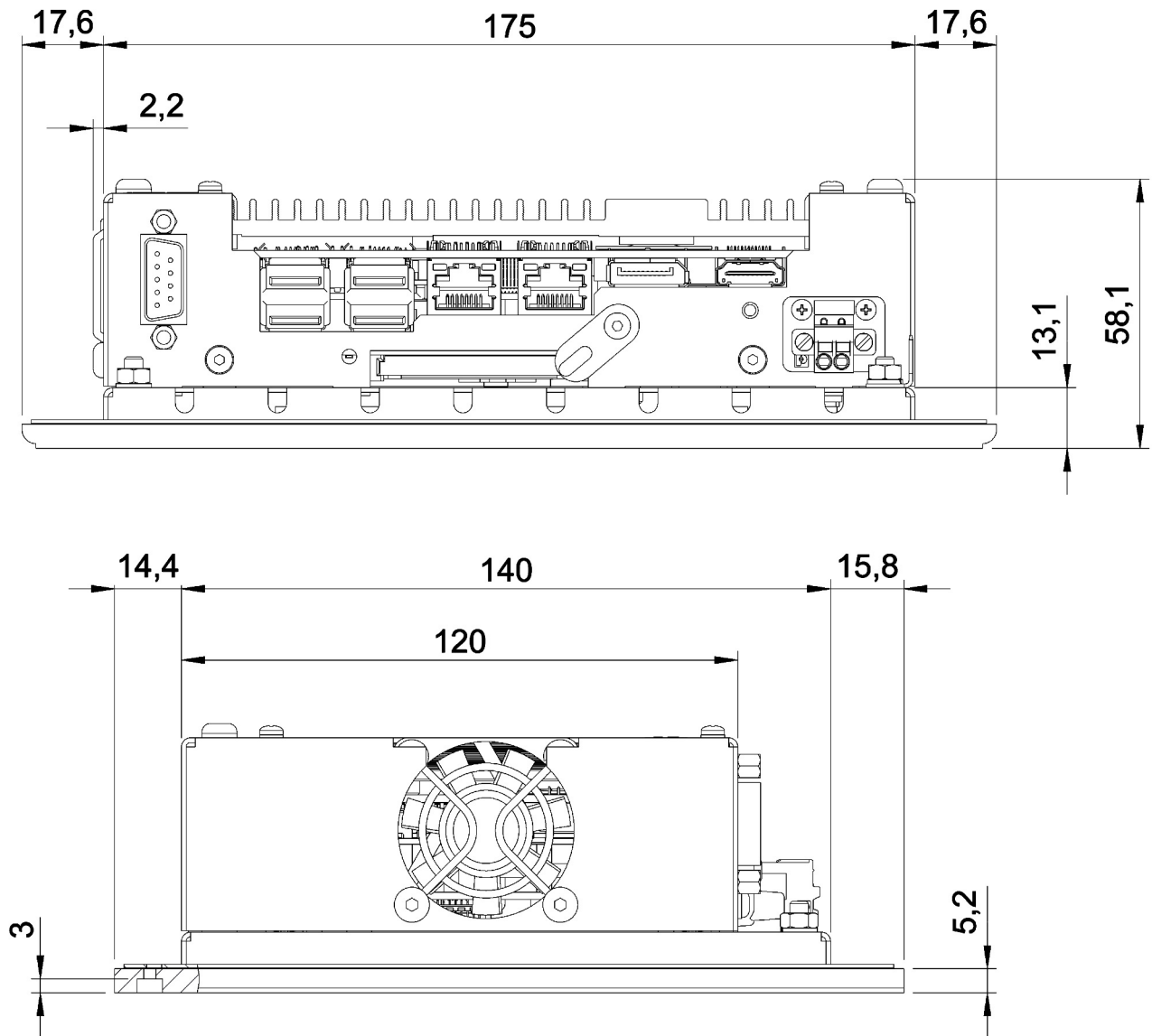

5.3.3 Rear view (recommended panel cut)

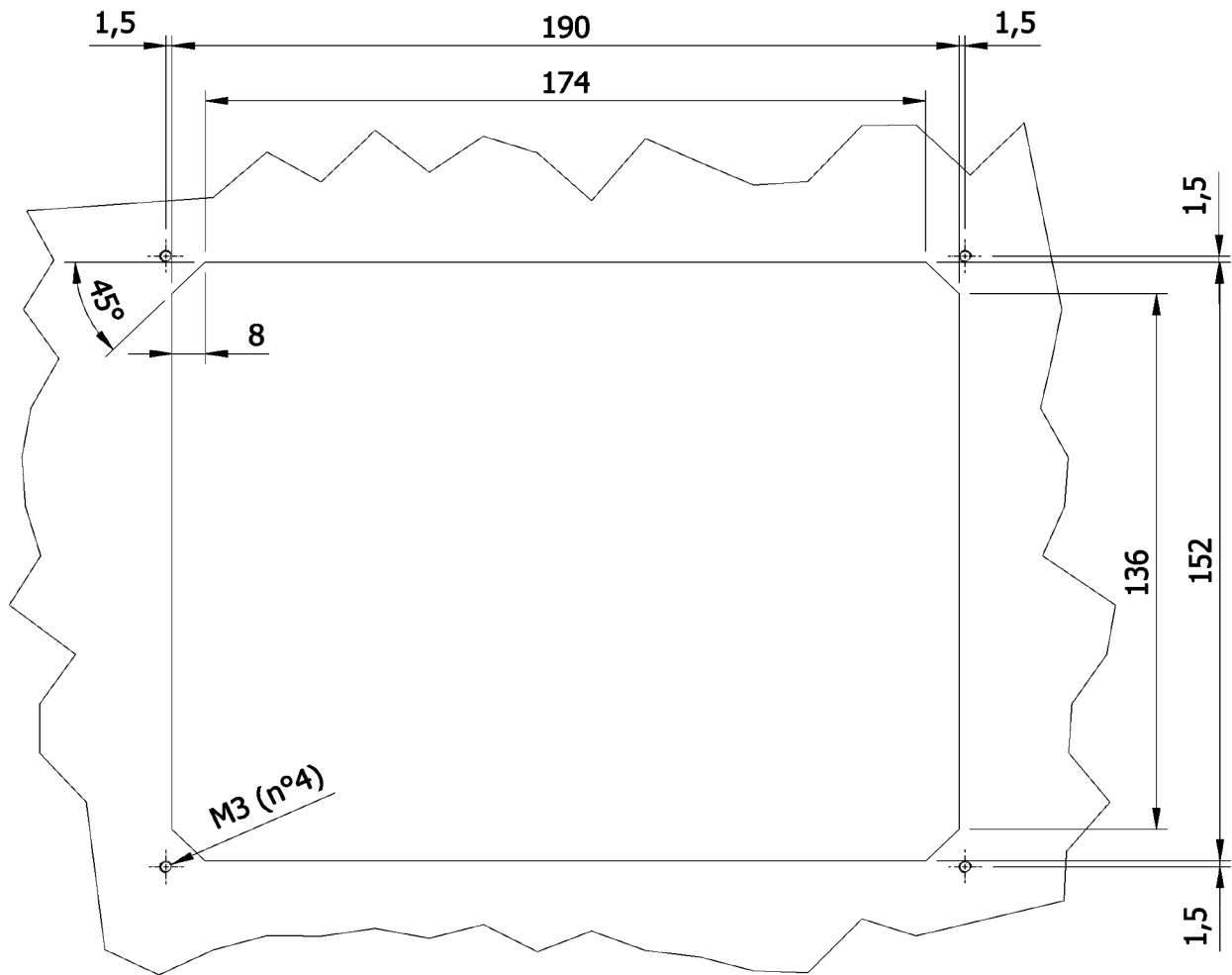

5.4 Hardware features

5.4.1 Basic Hardware

Processor	Intel® Celeron® Quad Core N3160 (1.60GHz)
Memory	4GB DDR3 1600MHz RAM
CFast card	32GB
Display	7 "color LED TFT, 800x480,262K colors
Touch screen sensor	4 resistive wires
Touch screen controller	USB
Serial port COM1	RS485 not isolated
DP port	1
Rear USB ports	4 x 3.0
Ethernet ports	2 x Gigabit LAN
HDMI ports	1

5.5 Order codes

Order codes	Model	Description
KZ010495	3303	POSYC 3303

5.6 Accessories

The POSYC 3303 industrial PC is supplied complete with power supply connector and mass storage memories. These items can also be ordered separately, like the other accessories not included in the POSYC 321X. Here is a list of the order codes:

Order codes	Merchandise
KF101074	24VDC detachable connector (Phoenix Contact 1851232; supplied with Posyc)
KE020031	Empty 32GB CFast Card
KE050087	CFast Card 32GB with OS W10IOT ENTERPRISE LTSB 2016
TB010554	CR2032 lithium coin cell battery
MA804900	Single-adhesive urethane foam seal

6 Connections and LEDs

The connectors are located in the upper part of the POSYC, as shown in the following figures.

6.1 Connections side view

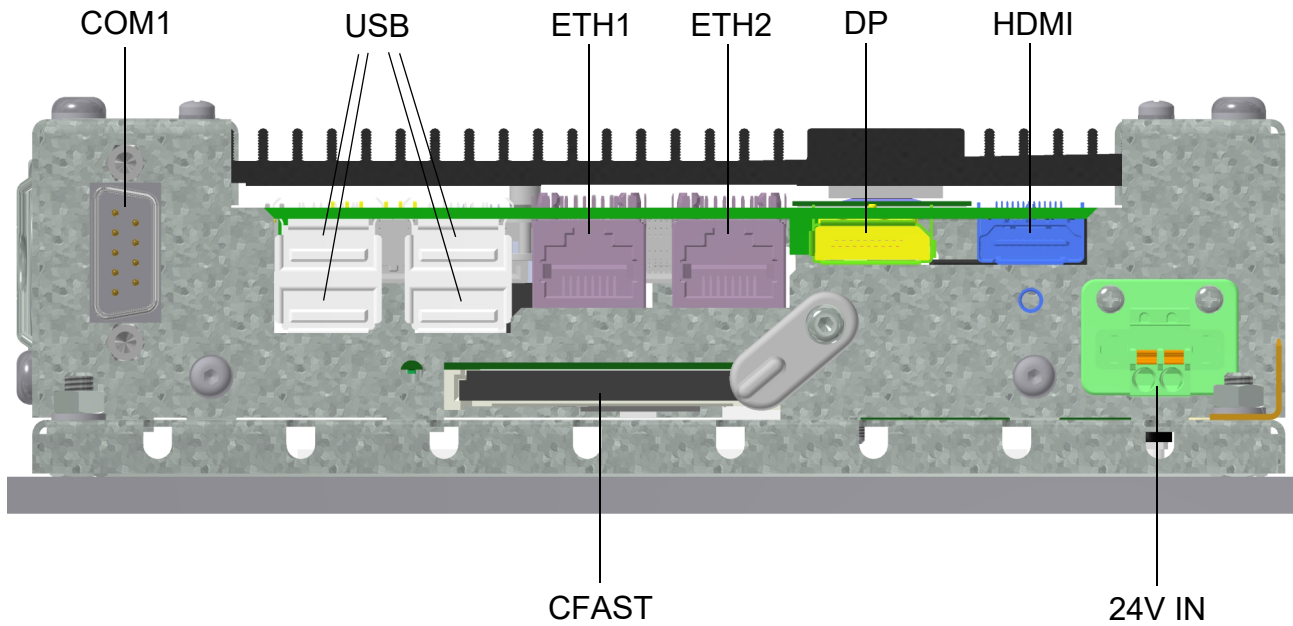

Name	Function
COM1	RS485 serial communication port
DP	DisplayPort video port
ETH1	Ethernet communication port 1
ETH2	Ethernet communication port 2
USB	4 x USB port 3.0
HDMI	HDMI audio / video interface port
24V IN	24V power supply connection
CFAST	CFast memory slot



Name	Function
PWR LED	White LED signaling POSYC on
HDD LED	White LED signaling activity CFast

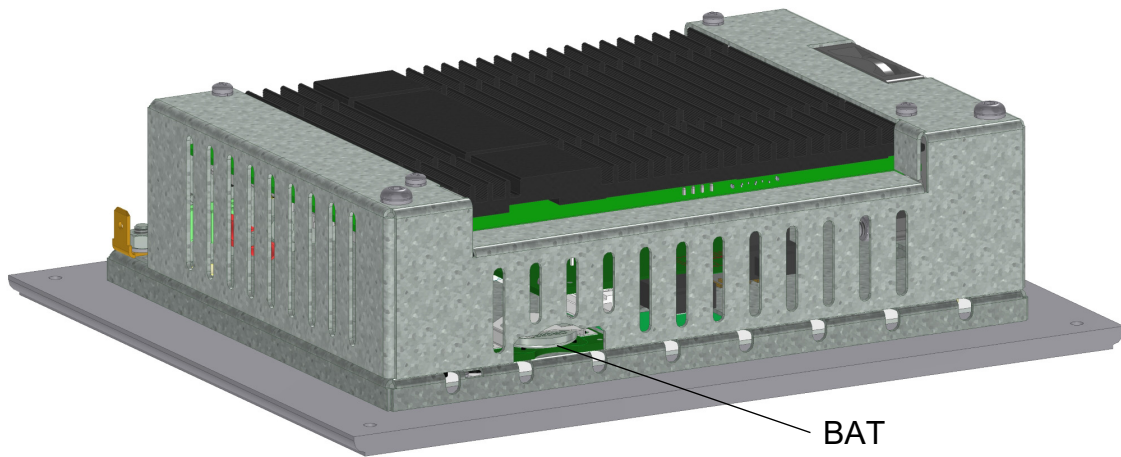

Name	Function
BAT	CR2032 button battery slot

6.2 24V IN supply connector

The connector which powers the POSYC 3303 features spring contacts, in order to make the wiring of single cables easier.

Connector type: Phoenix Contact FK-MCP 1,5/2-STF-3.81 (1851232) * **				
Order code: KF101074				
Features		Conductors cross section		
Connection in accordance with	EN-VDE	Solid min.	0,14 mm ²	24 AWG
Rated voltage	320 V	Solid max.	1,5 mm ²	16 AWG
Rated current	8 A	Stranded min.	0,14 mm ²	24 AWG
		Stranded max.	1,5 mm ²	16 AWG
Insulating material	PA	Stranded, with ferrule without plastic sleeve min.	0,25 mm ²	24 AWG
Inflammability class according to UL 94	V0	Stranded, with ferrule without plastic sleeve max.	1,5 mm ²	16 AWG
Stripping length	9 mm	Stranded, with ferrule with plastic sleeve min.	0,25 mm ²	24 AWG
Screwdriver to be used for opening the connections	0,4 x 2,5 mm	Stranded, with ferrule with plastic sleeve max.	0,5 mm ²	16 AWG
*= Use only 75°C cables **= Use only copper conductors				

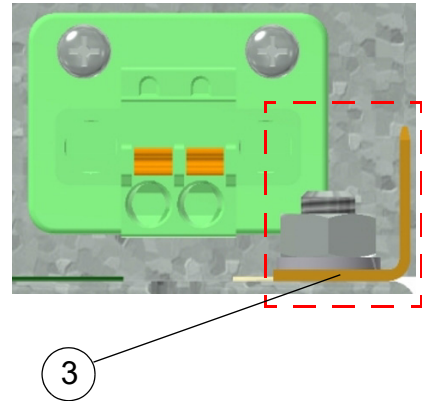
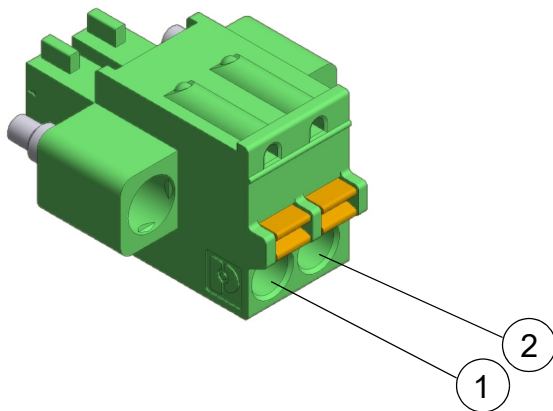

24V power supply	
Pin	Signal
1	+24 VDC
2	GND
3	FE (functional earth) on 6.3mm male faston adjacent to the connector

CAUTION

	<p>Use a cable with a suitable cross-section, sized correctly according to the through-current. A cable with a section smaller than that required may cause fire due to overheating phenomena generated by the cable itself.</p>
	<p>To ensure compliance with the EMC 2014/30 / EU directive, the length of the cables must not exceed a length of 30 meters.</p>
	<p>The POSYC 3303 is a high-tech electronic device, sensitive to electrostatic discharge (ESD) phenomena. Pay the utmost attention to prevent such phenomena, complying with the provisions of the law, in order to avoid damage to the device.</p>

ATTENTION

	<p>Utilisez un câble de section appropriée, dimensionné correctement en fonction du courant traversant. Un câble de section inférieure à celle requise peut provoquer un incendie en raison de phénomènes de surchauffe générés par le câble lui-même.</p>
	<p>Pour garantir la conformité avec la directive EMC 2014/30 / EU, la longueur des câbles ne doit pas dépasser 30 mètres.</p>
	<p>Le POSYC 3303 est un appareil électronique de haute technologie, sensible aux phénomènes de décharge électrostatique (ESD). Faites très attention à ce que ces phénomènes ne se produisent pas, dans le respect des dispositions légales, afin d'endommager l'appareil.</p>

6.3 RS485 serial port - COM1

Below is the pinout of the DB9 male connector on the Posyc.

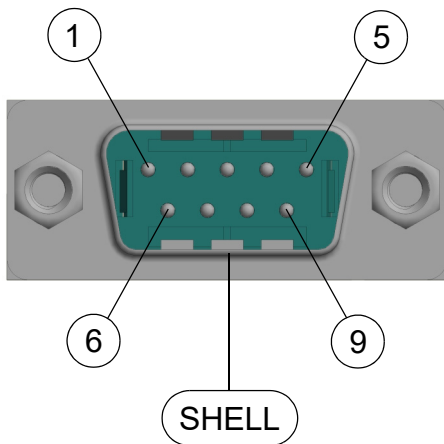

Serial RS485 - COM1	
Pin	Signal
1	DATA -
2	DATA +
5	GND
SHELL	CABLE SCREEN

6.4 Ethernet connectors

With the operating system loaded on the KE050087 memory card supplied, the two Ethernet ports ETH1 and ETH2 have different functions.

Use the ETH1 connector if you want to connect the Posyc to the local network.

Use the ETH2 connector if you want to connect the Posyc to the “Marts o MST” device.

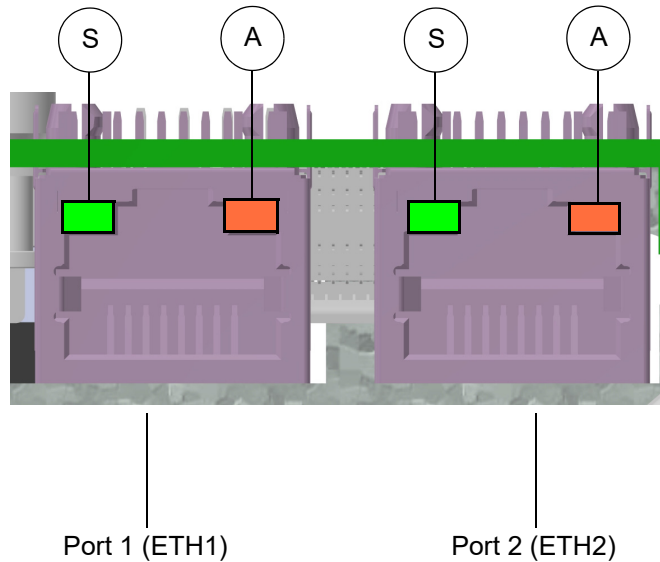

Each of the two Ethernet ports has two LEDs. The first, marked by the letter S, indicates the communication speed of the port involved. It is a two-color LED (green / orange); according to the speed at which the Ethernet port is communicating, the LED takes on a different color. The second, orange, marked by the letter A, indicates the state of activity of the door itself, or if the door is connected or if it is communicating.

6.4.1 LED behavior for signaling of communication speed

Name	State	Function
S	OFF	Ethernet port communicating at a speed equal to 10 Mbps
S	ON (green LED)	Ethernet port communicating at a speed equal to 100 Mbps
S	ON (orange LED)	Ethernet port communicating at a speed equal to 1 Gbps

6.4.2 LED behavior for signaling connection and communication activities

Name	State	Function
A	OFF	Ethernet port not connected
A	ON (orange LED)	Ethernet port connected
A	BLINK OFF (orange LED)	Ethernet port communicating



6.5 CFast card connectors

At the bottom of the POSYC, the CFast memory card connector is instead found. The memory is secured inside the computer by blocking a lever.

6.6 Battery slot

At the top of POSYC, there is instead the slot where the CR2032 button battery is housed. It is easily replaceable; its replacement is described later in paragraph 9.2 of the chapter "Ordinary maintenance".

7 Installation

	<p>During installation of the POSYC 3303 computer, falls and violent shocks must be avoided which could compromise the smooth operation.</p>
	<p>Avoid touching the input / output connectors on the computer panel directly unless you are equipped with suitable static electricity protection equipment; any discharges on the connectors could damage the appliance.</p>
	<p>Since the front panel integrates the touch screen sensor, violent blows in addition to damaging it irreparably could bring to light cut-glass shards, therefore dangerous for the operator.</p>
	<p>Always carry out all electrical connections when the equipment is switched off: this will prevent damage to the computer and danger to the operator (exceptions to connections to the USB ports are possible).</p>
	<p>Always make sure that all the devices connected to the POSYC have an efficient grounding (if foreseen by the device). Failure to follow this precaution could result in damage to the computer and danger to the operator.</p>
	<p>Do not position the device so that it is difficult to disconnect the wiring connected to it.</p>

7.1 Panel assembly

The POSYC can be mounted on the panel by preparing the recommended cut on a panel that is strong enough to support its weight and to remain flat once the computer is fixed. A lack of flatness can compromise the effectiveness of the installed gasket. For fixing use 4 M3 steel screws with cylindrical head (not supplied).

7.2 Environmental requirements

The POSYC is designed to be placed in a container that gives it protection from water and dust that could damage it.

The internal cooling of the POSYC takes place through the air sucked sideways by a high speed fan; in order for the system to work properly it must remain within the room temperature limits given in the specifications. All this implies that within the panel that will surround the POSYC, there must be suitable conditioning systems to keep the temperature within the accepted limits.

7.3 Electrical wiring

The main connections for the POSYC operation are the power supply and the earth; make these connections following the instructions on polarity, conductors and connectors stated in the chapter "Connections". Before switching on the computer, make sure that the mains voltage is within the parameters indicated in the specifications.

The device connection to the peripheral units is simplified by the use of standard computer connectors; this means that all standard peripheral for personal computers can be connected by means of the cable supplied with them or by means of commercial cables easily found on the market.

For connections to non-standard devices, such as inverters or other that require particular combinations of signals and cable lengths, it is possible to make them following the instructions stated in the chapter "Connections".

The following are some recommendations on how to make the cabling for serial communication.

7.3.1 RS485 serial port wiring

The typical use of RS485 ports is in multipoint configuration, or more devices connected to each other; this type of connection exploits a single pair of conductors and from this it follows that the communication is of the half-duplex type.

Through the RS485 serial ports, up to 32 devices (including the master) can be connected in a single section, offering good noise immunity and a maximum transmission speed.

According to the specifications of the RS485 standard the maximum length of the section is 1200mt at a maximum transmission speed of 100kbps. Please note that the length of the section is inversely proportional to the communication speed.

Through appropriate repeater devices (maximum 9) it is possible to extend the connection and connect up to 126 devices.

	<p>For correct operation it is necessary to use a suitable cable, terminating it appropriately. The termination consists in connecting at the beginning and at the end of the section of the resistors with a value of 120ohm; for the beginning and end of the section, the master and the most remote slave are considered respectively (called 1 and 4 in the figure below). The length of the cable connecting the intermediate line (called 2 and 3 in the figure below) must be as short as possible (in any case below 1mt), otherwise the signal quality will be lost. The RS485 serial ports of the POSYC have the termination resistors connected internally.</p>
---	---

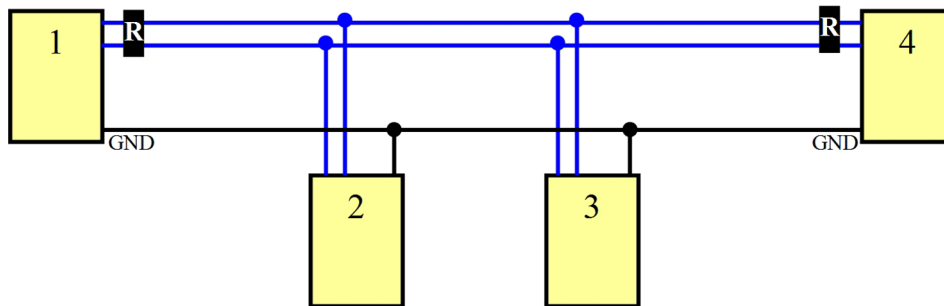

Example of RS485 wiring

An additional conductor with respect to the pair necessary for the communication that connects the masses to each other considerably reduces the probability of failure of the serial ports, especially if they are not isolated, which could form part of equipment with very different ground references.

	<p>It is good practice to ground the shield of the cable used only at one end (preferentially from the computer side) to avoid that potential differences between the two devices create a current circulation on the wiring screen, thus introducing communication disturbances; in some applications it is however possible to connect to both ends. The non-connection of the screen to the ground instead (disconnected from both ends) nullifies the function of the screen itself.</p>
---	--

7.3.2 Serial signals RS485 port

The following figures show the waveforms detected by means of an oscilloscope in different connection situations.

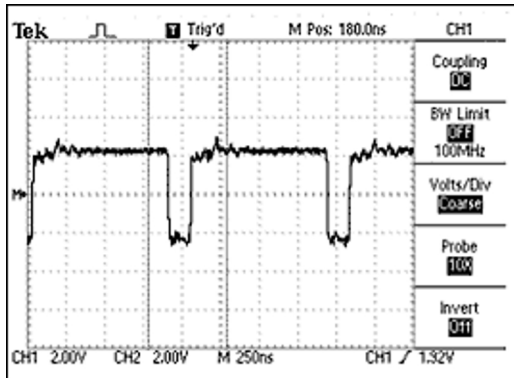

Example of a correct signal

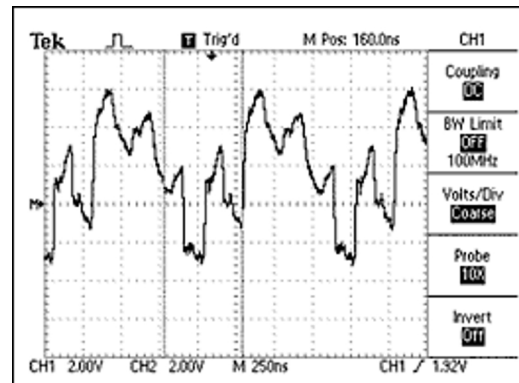

Example of a signal with unfinished lines

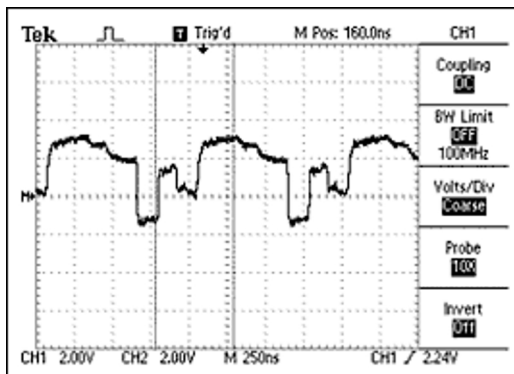

Example of a signal with placed terminations on the wrong device

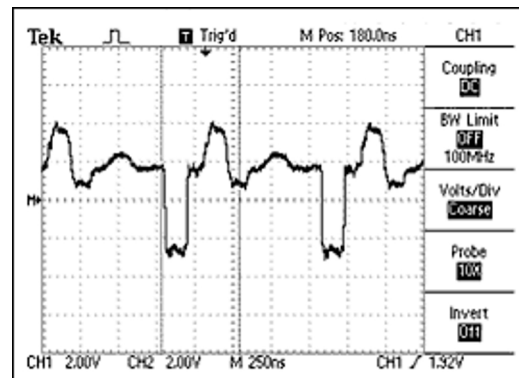

Example of a signal with incorrect value terminations

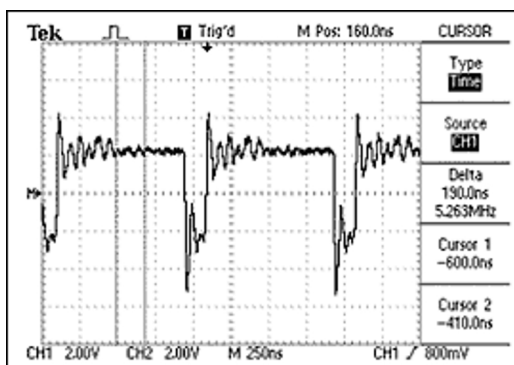

Example of signal on intermediate devices with long connections

8 Device use

8.1 Touch screen

The use of the POSYC computer is very similar to a normal desktop computer; the only substantial difference is the touch screen pointing device which, however, allows an even more intuitive use of the computer.

CAUTION

	<p>Operate the touch screen sensor only with your fingers or soft and not sharp objects, otherwise you will damage it.</p>
---	--

ATTENTION

	<p>Utilisez le capteur d'écran tactile uniquement avec vos doigts ou des objets mous et non tranchants, sinon vous risqueriez de l'endommager.</p>
--	--

To operate the touch screen, a slight pressure is sufficient (this has the appearance of any glass plate) to command the operating system pointer to move below the area where the pressure has been exerted. Depending on the software settings, the touch screen simulates dragging, clicking, double clicking and right mouse button. Refer to the software manual for further details.

8.2 CFast card

The CFast card of the POSYC replaces the traditional hard disk, thus ensuring better shock tolerance and longer life of the device, also in case of continuous working cycles.

The positioning of the flash CFast card and the simplicity of extraction / insertion allow its quick replacement both in case of failure and off-line software update.

CAUTION

	<p>To avoid computer failure and/or data loss to the CFast card, the replacement of the same must be done exclusively at POSYC turned off.</p>
---	--

ATTENTION

Pour éviter toute panne d'ordinateur et / ou toute perte de données sur la carte CFast, son remplacement doit être effectué exclusivement à POSYC off.

8.3 Priority of the start-up devices

“Start-up devices” refer to the CFast card or to the USB flash disk or to other mass memories where the operating system is stored (for example Windows) which start up the computer.

As a standard factory setup, the research of the operating system first occurs in the CFast, then in the USB flash disk whenever present. The first device of them that contains the start-up informations needed by an operating system for starting is used.

Therefore, if you want to start up the computer according to a different sequence, it is necessary to modify the setting in the CMOS Setup or remove any other start-up devices (for example, by removing the CFast).

According to the functioning mode of the BIOS in the POSYC, the start-up sequence automatically follows the variations of the quantity or serial numbers of the start-up devices; in fact the new devices, that were not present at the previous start-up, are listed as the last ones in the start-up sequence.

From this it follows that, for example, by replacing the CFast that contained the operating system, it is not used for startup when it is turned on; it is therefore necessary to correct the setting in CMOS Setup (see paragraph 10.3) or temporarily disconnect the other start devices.

If necessary, then, via the USB keyboard connected to the POSYC, enter CMOS Setup by accessing it using the STECH password (power the computer and as soon as the Smitec logo appears, press the Del/Delete key on the keyboard).

Be careful not to modify any other parameter, otherwise the device will not work.

8.4 Power ON

When the POSYC 3303 is powered, for about 4 seconds the device will switch on and then switch off for the same period of time. Subsequently, the device will restart, with the peculiarity that the cooling fan will initially run slowly and then increase its speed until it is working.

9 Ordinary maintenance

9.1 Cleaning the touch screen sensor

The cleaning of the touch-screen sensor must take place rather frequently to avoid the stratification of the dirt derived from the hands or from materials that were accidentally in contact with its surface and to maintain the best possible visibility of the display.

If necessary, the front of the device (keyboard and viewing window) can be cleaned with a very soft cleaning cloth (recommended in microfibre) dampened with water or cleaning solution for display.

9.2 Clock battery replacement

The replacement of the internal clock battery, in addition to ensuring the maintenance of the same, is useful not to lose the settings of the CMOS Setup (basic information for the operation of the computer).

Depending on the climate and how the computer is used, this can have a very variable duration starting from the POSYC production date.

It is therefore suggested to carry out the preventive battery replacement at least every 2 years taking care to always use the exact model (3V lithium battery - CR2032).

To replace it, simply remove the battery from its slot located at the top of POSYC 3303, then with the power off, replace the battery with a new one. To simplify the replacement, use a small screwdriver to pry it gently so that the battery protrudes slightly from its slot and then be able to grasp it easily and then pull it out.

Pay attention to the way in which the new battery is inserted in its slot, respecting the polarity as shown in the following image:

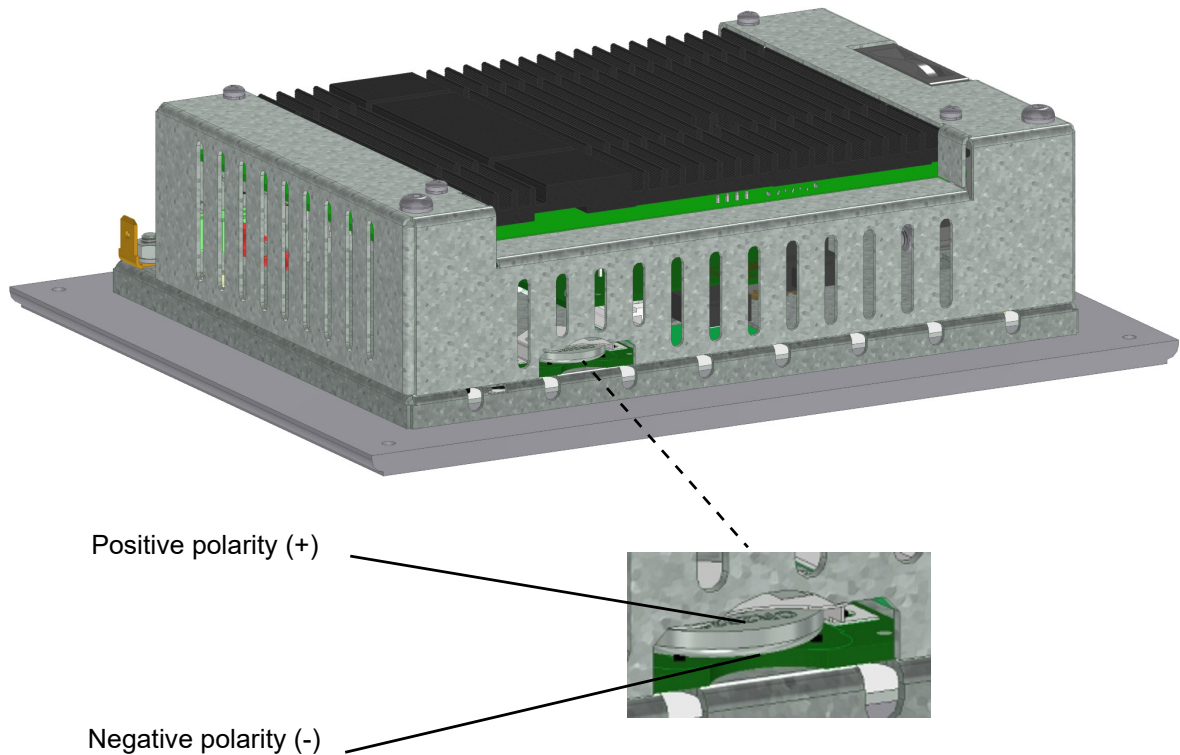

If the existing battery is not completely discharged, performing the replacement operation in a few seconds, it will not be necessary to correct the date / time of the CMOS Setup.

9.3 CFast replacement

If it is necessary to replace the 32GB CFast flash disk (KE050087), the BIOS automatically changes its Boot settings. To allow the POSYC to be properly set up with the operating system installed on the new CFast, or Windows 10, it is necessary to modify the BIOS/CMOS parameters as described below:

- **Boot**
- **Boot Option #1**
- **UEFI: Built-in EFI Shell** replace with **Windows Boot Manager (P0: CFast 3ME4)**

- **Boot**
- **Boot Option #2**
- **UEFI: Built-in EFI Shell** replace with **Disabled**

Then save the modified parameters in this way:

- **Save & Exit**
- **Save Changes and Reset**
- The "**Save configuration and reset ?**" window opens automatically
- Confirm with the "**Yes**" keyboard

9.4 BIOS update

If it is necessary to reinstall the BIOS via a dedicated USB key, change the BIOS/CMOS parameters as described below:

- **Boot**
- **CSM Support**
- **Disabled** replace with **Enabled**

Then save the modified parameters in this way:

- **Save & Exit**
- **Save Changes and Reset**
- The "**Save configuration and reset ?**" window opens automatically
- Confirm with the "**Yes**" keyboard

10 Appendices

10.1 Appendix I: CMOS Setup parameters

In POSYC 3303, the CMOS Setup parameters are stored in the BIOS to guarantee operation.

In the event that there is a loss of memory of the CMOS Setup, for example after the backup battery has been used up, the parameters are automatically restored when the POSYC starts up, with the exception of the date and time, which can however be reset via the operating system.

If the parameters are to be changed incorrectly, they can be reset using the "Load Optimized Defaults" function in the "Save&Exit" menu of the CMOS Setup.

10.2 Appendix II: OS update and/or software installation

For security reasons and to maintain system integrity, the "Windows Module Installer" service is disabled; therefore, if it is necessary to perform operating system updates and/or system software installation, it is recommended to re-enable it only temporarily.

11 Analytical index

A

Absorbed current	9
Absorbed power	9
Accessories	14
Assembly	6

B

Battery	21
BIOS	27

C

CFast	7, 13, 26
Cleaning	28
Clock battery	28
CMOS	28
CMOS Setup	27, 31
COM1	13, 19
CR2032	14, 21, 28

D

Display	13
DP	7, 13

E

Ethernet	7, 13, 20
----------------	-----------

F

Fastening	10
FE	18
Front view	8, 10

H

Handling	6
HDD LED	16
HDMI	7, 13, 15
HMI	7

I

Installation	22
--------------------	----

L

LAN	13
LEDs	15

M

Memory	13
Merchandise	14

O

Order codes	14
-------------------	----

P

Panel cut	12
Processor	7, 13
Protection degree	9
PWR LED	16

R

RAM	7
Relative humidity	9
RS485	7, 13, 23

S

Sensor	28
Serial signals	25
Start-up	27

T

Touch screen	13, 26
--------------------	--------

U

USB	7, 13
-----------	-------

W

Weight	10
--------------	----