



ETHERCAP

Ethernet rotary coupler

Description

10/100BASE-T Ethernet rotary coupler for industrial applications, housed in an IP54 tiny aluminum case. Capacitive coupling technology allows high-speed contactless communications between revolving parts on machinery and robots. Tested on high-speed real-time SERCOSIII™ protocol, it is ideal for Ethernet-based fieldbuses. The connections to power supply and to fieldbus are made by robust M12 connectors placed aside the disks or longitudinally, depending on the product version.

Technical data

Ethernet compliance	10/100BASE-T IEEE 802.3 compliant
Coupling method	capacitive
Housing material	aluminum
Degree of protection	IP54
Shaft bore	22 mm
Rotating speed	Up to 40 rpm
Electrical specifications	Power supplies: 2 x 24VDC, 2W max. M12 A-coded connectors (power supplies) M12 D-coded connectors (Ethernet)
Environmental specifications	operating temperature from +5°C to +55°C storage temperature from -40°C to +70°C relative humidity from 10% to 95% (non condensing)

Dimensions

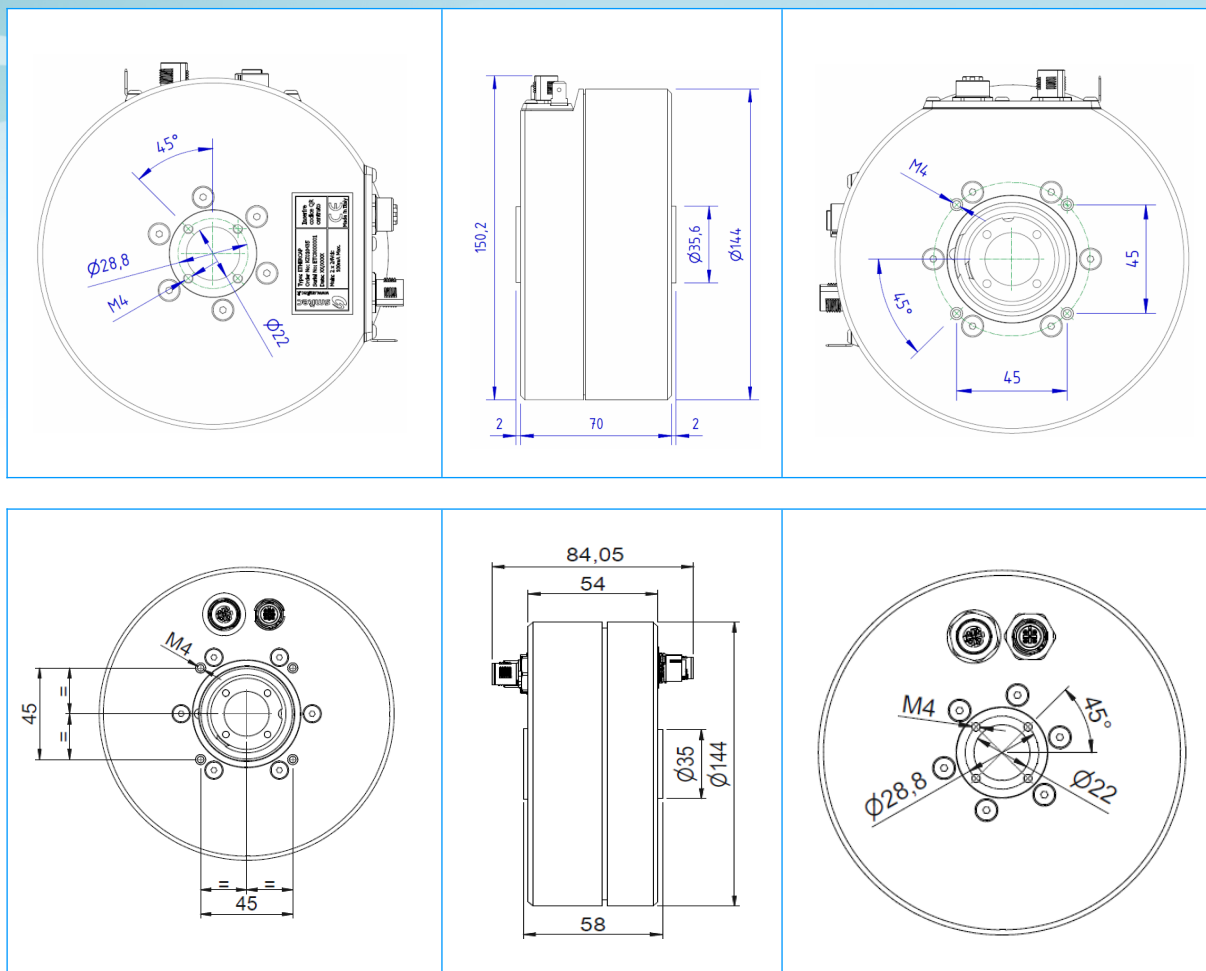

Data here mentioned may be subject to changes without any notice.