

ICOS 3210

Integrated digital servodrive

High performance integrated digital servodrive. Designed for challenging applications on modern machinery, it offers extraordinary flexibility thanks to reliable real-time buses and sophisticated control algorithms. Available with proprietary FLXIO™ interfaces for demanding real-time applications with the use of Sercos III™, Ethercat and Modbus TCP gateways.



Smittec S.p.A.

Via Carlo Ceresa, 10 - 24015 San Giovanni Bianco (BG) ITALY

Tel. +39 0345 40.111 - www.smittec.it

P.I.: 04471940165 - C.F.: 03942700166

Technical specifications	
Housing	Painted aluminum
Degree of protection	IP65
Motors	Brushless
Nominal current	5.6 A _{RMS}
Peak current	20 A
Encoder	Incremental/Hiperface multiturn
Digital I/O	4 I/O up to 1A overall 2 Input 24V high speed and normalized
Analog I/O	1 Input 4-20mA
Bus interface	Isolated proprietary FLXIO™ Available SERCOS III™, Ethercat, Modbus TCP gateways
Operator interface (optional)	By VISIO connected to the I/O connector
Power connection	1 M12 Power cod. S connector – Without daisychain
Vaux connection	1 M12 cod. A connector – Without daisychain
I/O connection	DB 15 HD connector
Electrical specification	Main Power supply: 325 V _{DC} Vaux: 24 V _{DC} -15%÷+10%
Environmental specifications	Operating temperature from +0°C to +55°C (without derating up to 40°C) Relative humidity from 5% to 85% (noncondensing)
Power supply	Available the ICOS-PS 3161 power supply with 16A in three phases configuration or 9A in single phase configuration

Dimensions

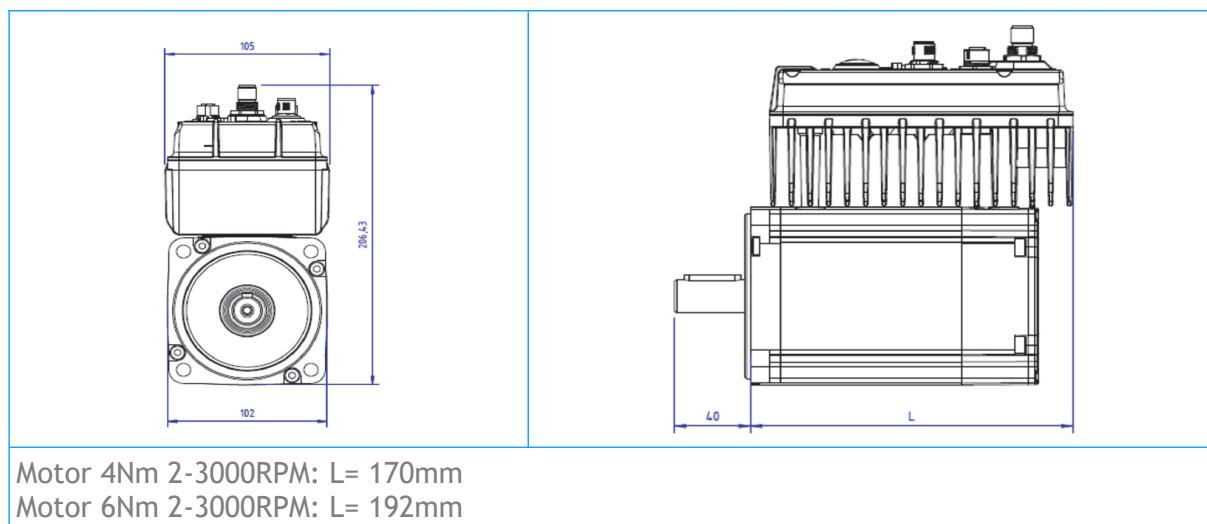

Data here mentioned are subject to changes without any notice.