

Smitec S.p.A., via Carlo Ceresa 10, 24015 San Giovanni Bianco (BG), Italy, [www.smitec.it](http://www.smitec.it)



## Installation, use and maintenance manual



**BEFORE STARTING UP THE SERVOMOTOR ICOS 3110, CAREFULLY READ THIS MANUAL AND FOLLOW ALL INSTRUCTIONS, IN ORDER TO ENSURE MAXIMUM SAFETY**

# SERVOMOTOR WITH INTEGRATED DRIVE ICOS 3110



The technical data and the drawings in this manual might have been modified later; always refer to the latest version.

## Summary

<b>1 Preface</b> .....	<b>3</b>
<b>2 General warnings</b> .....	<b>4</b>
<b>3 Safety instructions</b> .....	<b>6</b>
3.1 General information .....	6
3.2 Precautions during handling and assembly .....	6
3.3 Precautions against risk of Electric Shock .....	7
3.4 Precautions against hot components .....	7
3.5 Residual risks .....	8
3.6 Limitations of use .....	8
<b>4 Data sheet</b> .....	<b>9</b>
4.1 Description .....	9
4.2 Reference documents .....	10
4.3 Technical data .....	10
4.3.1 Mechanical characteristics .....	10
4.3.2 Environmental specifications .....	11
4.3.3 Power supply .....	12
4.3.4 Digital inputs .....	12
4.3.5 Configurations / order codes .....	12
4.4 Accessories .....	13
4.5 Electromagnetic compatibility (EMC) .....	13
4.6 Mechanical specifications .....	14
4.6.1 Weight .....	14
4.6.2 Size .....	14
<b>5 Installation and start-up</b> .....	<b>15</b>
5.1 Preliminary operations .....	15
5.2 Installation mode .....	16
5.3 Mechanical assembly .....	17
5.3.1 Fastening .....	17
5.3.2 Torque transmission .....	18
5.4 Connections and LEDs .....	19
5.4.1 DC-bus power supply - J3 .....	20
5.4.1.1 Conductors and protective devices .....	23
5.4.1.1.1 Protection for UL applications .....	23
5.4.1.1.2 Protection for other applications .....	23
5.4.2 FlxIO field bus - J1 .....	25
5.4.3 Auxiliary power supply 24V - J4 .....	27
5.4.4 Digital inputs and power supply with 24V output - J2 .....	29
5.4.4.1 24V digital inputs .....	30
5.4.5 LEDs .....	31
5.4.5.1 References signaling LEDs (STS) .....	31
5.4.5.2 LED1 behavior .....	32
5.4.5.3 LED2 and LED3 behavior .....	32
5.4.6 Installation criteria for UL certification .....	33
5.5 Addressing .....	34
5.5.1 Manual addressing .....	34
<b>6 Firmware upgrade</b> .....	<b>36</b>
<b>7 Storage</b> .....	<b>37</b>
<b>8 Maintenance</b> .....	<b>38</b>
<b>9 Disposal and demolition</b> .....	<b>39</b>
<b>10 Analytical index</b> .....	<b>40</b>

## 1 Preface

This manual provides all necessary information for the installation, use and maintenance of the servodrive ICOS 3110.

The instructions included in this manual are addressed to the following professionals:

<b>User</b>	User is a person, a company or an institution that buys the equipment and uses it for the purposes it was designed for.
<b>User/operator</b>	User or operator is a person authorized by the user to operate on the equipment.
<b>Specialized personnel</b>	It refers to all persons with specific competence, able to recognize and avoid the dangers deriving from the use of the equipment.

The present instructions must be made available to all the above individuals.





## 2 General warnings



These assembly instructions are an integral part of the equipment, and must be kept for future reference until it decommissioned.

The user should be informed that the present instructions reflect the state of the art at the moment when the equipment was sold; they will remain fully acceptable despite subsequent upgrades based on new technical update.

	<p><b>DO NOT USE THE EQUIPMENT, NOR MAKE ANY INTERVENTION BEFORE INTEGRALLY READING AND UNDERSTANDING THIS MANUAL.</b></p>
<p><b>IN PARTICULAR, ADOPT ALL SAFETY PRECAUTIONS AND PRESCRIPTIONS INDICATED IN THIS MANUAL.</b></p>	
<p><b>THE EQUIPMENT MUST NOT BE USED FOR PURPOSES DIFFERENT THAN THE ONES DESCRIBED IN THIS MANUAL; SMITEC S.p.A. SHALL NOT BE HELD RESPONSIBLE FOR ANY DAMAGES, INCONVENIENCES OR ACCIDENTS DUE TO THE NON-COMPLIANCE WITH THESE PRESCRIPTIONS.</b></p>	

In order to make the manual consultation easier, the following symbols have been adopted:

	<p>Indication of "PROHIBITED ACTION".</p>
	<p>The symbol "DANGER" is used when non-compliance with the prescriptions or misuse may cause serious injuries.</p>
	<p>The symbol "DANGER FROM HOT SURFACES" is used when non-compliance with the prescriptions or misuse may cause serious injuries.</p>
	<p>The symbol "DANGER FROM ELECTRICAL SHOCK" is used when non-compliance with the prescriptions or misuse may cause serious injuries.</p>



	<p>The symbol “USE OF INDIVIDUAL PROTECTIONS” means that protective gloves must be worn.</p>
	<p>The symbol “USE OF INDIVIDUAL PROTECTIONS” means that protective glasses must be worn.</p>
	<p>Indication of “INFORMATION OF PARTICULAR RELEVANCE”.</p>

The safety prescriptions aim at establishing a series of behaviors and obligations to be complied with, while performing the activities described later on in this manual.



These prescriptions constitute the prescribed method of operating the device, in a way that is safe for personnel, equipments and environment.

### 3 Safety instructions

#### 3.1 General information

	<p>Do not install or use the equipment before integrally reading and understanding this manual. In case of difficulties of interpretation, contact SMITEC technical service.</p> <p>It is absolutely forbidden to use the equipment for different purposes than the ones described in this manual. The technical data and the drawings in this manual might have been modified later; always refer to the latest version. All upgrades can be requested to SMITEC S.p.A. directly.</p>
	<p>Make sure that the personnel is qualified and adequately informed about the risks he may run and how to avoid them.</p>
	<p>Servodrive ICOS 3110 can be used only after classifying the final machine operating zone and after checking the safety levels, which must comply with the machine safety levels.</p>

#### 3.2 Precautions during handling and assembly

	<p>Use adequate tools during the assembly, in order to avoid crushing or abrasions.</p>
	<p>Metal components and sharp surfaces may cause cuts and tears. In case of contact, be very careful and wear the personal protection equipment.</p>

**3.3 Precautions against risk of Electric Shock**

	<p>The power supply connector is subject to high voltage during the servodrive operation; be careful (danger of Electric Shock).</p>
	<p>During installation and maintenance, disconnect the device from the mains power supply. Risk of Electric Shock.</p>
	<p>Some components (such as the aluminium heat sink) are made of conductive materials. They must be safely connected to the protective conductor (PE/Ground) by using the specific terminal strips, in order to avoid Electric Shock.</p>
	<p>Never use the device if it is partially or totally disassembled. Risk of Electric Shock and/or damages to people and properties.</p>

**3.4 Precautions against hot components**

**WARNING**

	<p>The parts of the apparatus can reach an extremely high temperature in operating mode or post-operation; take particular care not to touch the parts of the equipment in these cases, or use special protections and precautions during handling: Hot Surface, Risk of Burn.</p>
---	--

**AVERTISSEMENT**

	<p>Les pièces de l'appareil peuvent atteindre une température extrêmement élevée en mode de fonctionnement ou post-opération; veuillez particulièrement à ne pas toucher les pièces de l'équipement dans ces cas, ou utilisez des protections et des précautions spéciales lors de la manipulation: Surface Chaude, Risque de Brûlure.</p>
---	--

	<p>The manufacturer of a servodrive ICOS 3210 must take all precautions in order to avoid the operator's contact with hot components, to prevent the risk of burning.</p>
---	---

### 3.5 Residual risks

	<p>The apparatus generates an electromagnetic field during operation. Danger for people with pacemakers, metal prostheses or hearing aids.</p>
---	--

### 3.6 Limitations of use

	<p>The servodrive ICOS 3110 is not safety device; do not rely on them to carry out safety functions (for example: safe stop, safe reduced speed, etc...).</p>
	<p>The operating temperature range of the servodrive is 0 ÷ 55°C; the operating temperature range at rated current (without derating) is 0 ÷ 45°C.</p>



## 4 Data sheet

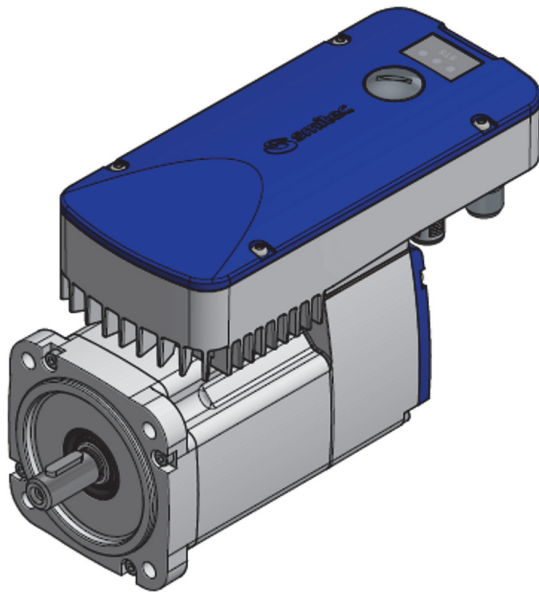

Front view

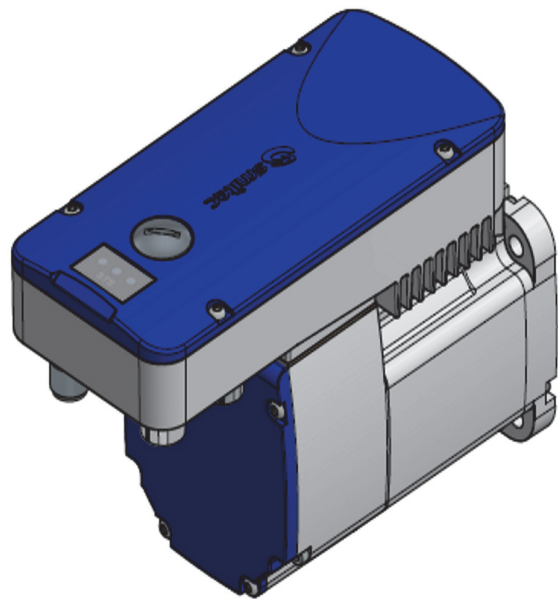

Rear view

### 4.1 Description

The servomotor ICOS 3110 is brushless AC servomotor (BLAC) with integrated servodrive. The aluminium case enables heat dissipation without needing external fans (“fanless”), forming an extremely compact and reliable unit. The motor is equipped with an incremental encoder.

The control unit, based on a microprocessor, controls an intelligent IGBT module (IPM), in order to ensure a sophisticated, reliable control of the motor. This is possible also thanks to the FixIO field bus, based on insulated, real-time RS 485 serial port. It is possible to check the speed, the position and the motor torque, in a very flexible way. It is possible to upgrade the firmware via field bus, in a quick way and without needing external connections. The field bus insulation ensures better immunity to EMC interferences and improves electrical ruggedness. The 32-bit microcontroller ensures a detailed diagnosis of the device, which is very useful during the system development phase.



To ensure maximum flexibility of use, the ICOS 3110-FB servomotor is equipped with 2 digital inputs, in order to allow interfacing with standard sensors.

4.2 Reference documents

Code	Description
DK400197	Use and programming manual ICOS 3XXX
DK400076	FLXIO / FLXMOD integration manual

4.3 Technical data

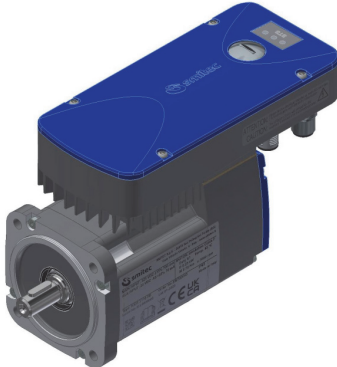
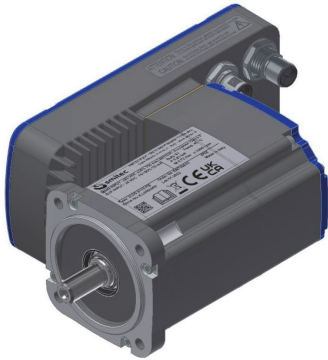
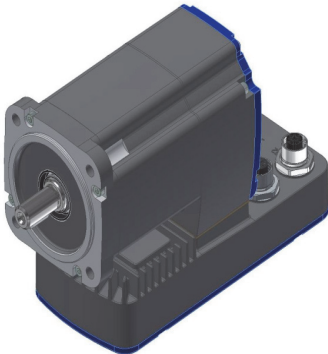
4.3.1 Mechanical characteristics

Delivered torque	Rated torque	Inrush torque			
	0.65 Nm	1.96 Nm			
Rotation speed	Rated speed	Maximum speed			
	3000 rpm	3250 rpm			
Mechanical power supplied to the shaft (it depends on the assembly position, as indicated in the pictures A, B, C and D)	A	B			
					
	C		D		
					
		A (kW)	B (kW)	C (kW)	D (kW)
EM700043	0.19	0.20	0.20	0.19	
<b>Rotor moment of inertia</b>	0.40 10 <sup>-4</sup> kg·m <sup>2</sup>				

Shaft diameter	11 mm
----------------	-------

4.3.2 Environmental specifications

Operating temperature (Maximum air temperature)	0° ÷ +45°C with full-load operation
	0° ÷ +55°C with derating of the delivered torque
Environment of use	Use in Pollution degree 2 Environment
Degree of protection	IP65
Air humidity during operation	5 ÷ 85% not condensing
Storage temperature	-25 ÷ +55°C
Air humidity during stocking	5 ÷ 95%
Air humidity during transportation	5 ÷ 95%
Maximum altitude	1000 m a.s.l. at rated output current
	2000 m a.s.l. with current derating

**Output current derating as a function of altitude**

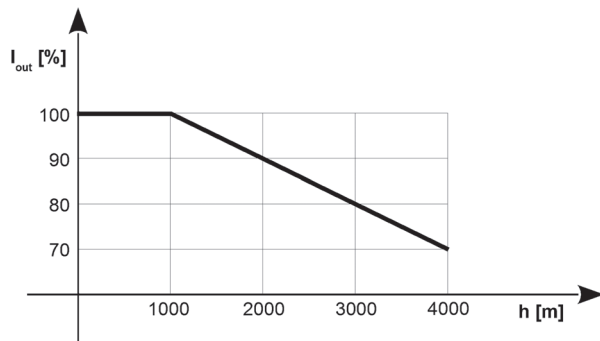

**Derating of the delivered torque as compared to the rated torque as a function of the environment temperature for motors EM700043.**  
 The possible assembly positions, previously described at paragraph 4.3.1 (Mechanical features) are indicated in the legend of the picture.

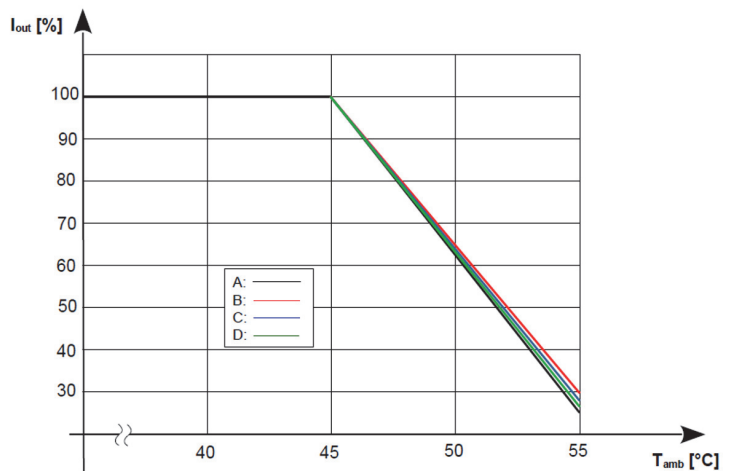

Derating of the torque delivered with respect to the nominal value [%]

For each of the 4 possible installation positions of the servomotor ICOS 3110 shown in paragraph 4.3.1, the maximum torque values that can be supplied continuously (duty S1) both at 45°C and at 55°C (derating) are declared in the following table.

Therefore, if it is possible, during the installation of the servomotor ICOS 3110, it is advisable to fix the device in position B, which has resulted to be the best performing among the 4 possible configurations.

	Maximum torque at 45°C	Maximum torque at 55°C
<b>Position A</b>	0.60 Nm	0.15 Nm
<b>Position B</b>	0.65 Nm	0.20 Nm
<b>Position C</b>	0.65 Nm	0.15 Nm
<b>Position D</b>	0.60 Nm	0.15 Nm

### 4.3.3 Power supply

<b>Mains voltage</b>	325 VDC ± 15%	
<b>Maximum short-circuit current</b>	5 kA at the installation point	
<b>Mains power supply max. absorption</b>	0.7A DC	
<b>Auxiliary mains voltage</b>	24 VDC -15 ÷ +20%; ripple max 5% of the rated value	
<b>Auxiliary mains power supply max. absorption</b>	24V_MAIN	70 mA
<b>Max. dispensing auxiliary power supply</b>	24V_I/O (protection 0.5A)	500 mA

### 4.3.4 Digital inputs

<b>Number of inputs</b>	2 digital inputs
<b>Type</b>	24 V digital inputs, compatible with type 1 and type 3, according to IEC 61131-2
<b>Input sampling interval</b>	1 ms min

### 4.3.5 Configurations / order codes

Up to date we defined some standard configurations of servodrives, with an order code and a number made of 4 figures and 2 letters, called “Type”, indicating the series, the maximum current, the hardware version, the communication bus and the controlled motors. The type is indicated on the servodrive label.

Order code	Model	Description
EM700043	ICOS 3110-FB-	Ø70 0.65Nm 230V 3000rpm incremental encoder

#### 4.4 Accessories

The following table lists the accessories of the servodrive ICOS 3110, including their order code:

Order code	Item
KZ010628	DC bus power supply unit ICOS-PS 3162
EP200328	Push-pull connector for the main power supply
KF131326	Connector with termination resistor for FxIO bus, type M12

#### 4.5 Electromagnetic compatibility (EMC)

The servodrives/inverters comply with EN IEC 61800-3 requirements for installation in environment 2 (“*Second environment*”), category C3. The servodrive must be installed according to the installation criteria described in the manual of the power supply unit ICOS-PS 31XX. The manual code is DK400183.

The servodrive installation can be considered as adequate when it complies with the installation criteria of its power supply unit (ICOS-PS) and no more than six servodrives (ICOS) are installed downstream.

The installer shall make sure that the device meets the standard requirements (EN IEC 61800-3 for the installation in environment 2 “*Second environment*”, category C3).

## 4.6 Mechanical specifications

### 4.6.1 Weight

The following table indicates the weight of the different models:

Type	Weight (kg)
EM700043	1.6 kg

### 4.6.2 Size

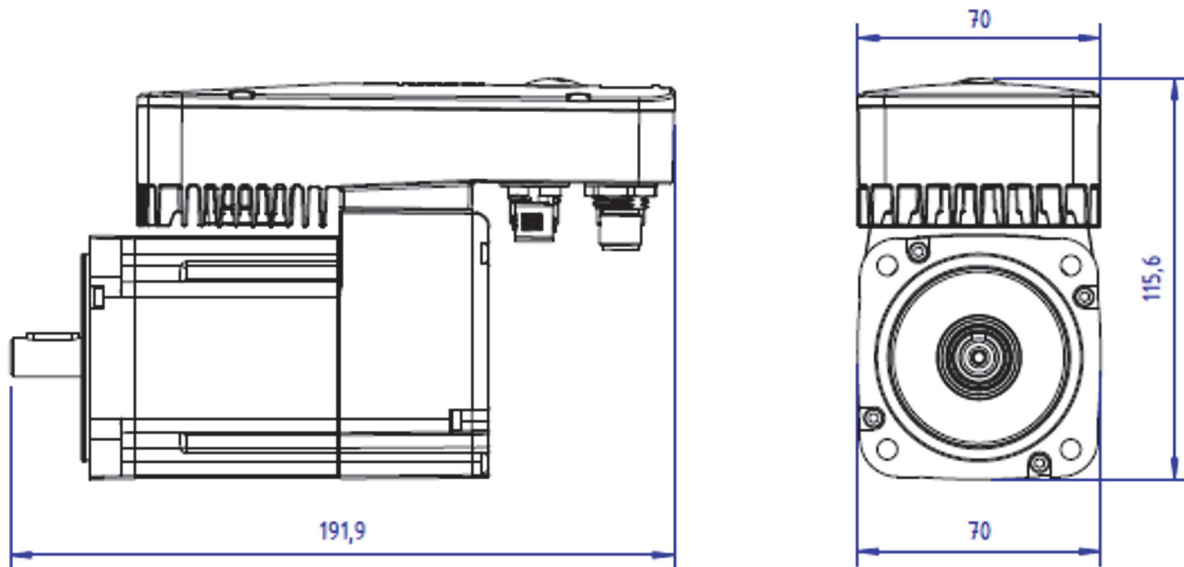

## 5 Installation and start-up

### 5.1 Preliminary operations

Before starting up the device, make the following checks:

- Check the perfect integrity of the device and its components.
- Make sure that all manuals necessary for installation are available.
- Read this manual integrally.

#### **WARNING**

	<p>Metal parts and all "live" parts can under certain conditions cause cuts and tears. Pay particular attention in case of contact and use suitable personal protective equipment (PPE).</p>
---	--

#### **AVERTISSEMENT**

	<p>Les pièces métalliques et toutes les pièces sous tension peuvent, dans certaines conditions, provoquer des coupures et des déchirures. Portez une attention particulière en cas de contact et utilisez un équipement de protection individuelle (EPI) approprié.</p>
---	---

#### **WARNING**

	<p>Use adequate tools during the assembly, in order to avoid crushing or abrasions.</p>
---	---

#### **AVERTISSEMENT**

	<p>Lors du montage de l'appareil, utilisez des outils appropriés pour éviter tout risque de blessure, d'écrasement, d'abrasion, etc.</p>
---	--

## 5.2 Installation mode

During the installation of the device, the upper and lower part and the side parts must have a free space of at least 100 mm compared to other electronic and / or mechanical components.

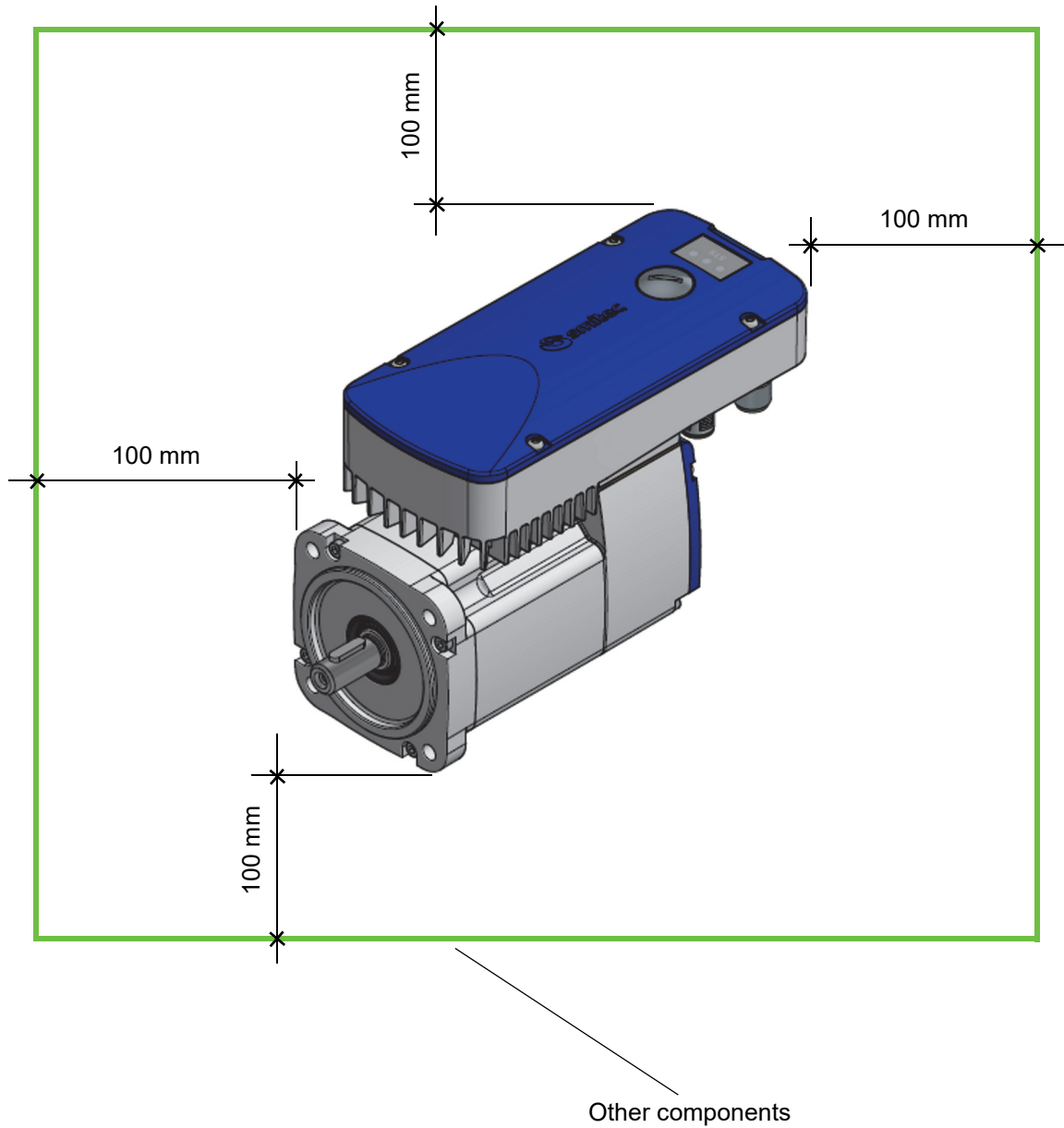



### 5.3 Mechanical assembly



#### 5.3.1 Fastening

Tighten the flange with steel bolts, 8.8 grade or higher grade. The recommended tightening torque is indicated in the following table, which refers to new bolts with not lubricated threads.

THREAD SIZE	TIGHTENING TORQUE [Nm]
M5	6

Reduce the tightening torque if the threads are lubricated (max. reduction 20% with MoS2 lubricant) Use flat washers for the bolts. In case of strong vibrations and/or shock loads, use Grover washers or apply threadlocker paste (Loctite 243 type or equivalent type).

Make sure the bearing surface is clean and flat (no dents or scratches, etc...), in order to avoid misalignment.

 	<p>During the servodrive assembly, always wear the personal protective equipment (PPE).</p>
---	---

### 5.3.2 Torque transmission

The torque is transmissible with direct coupling or with belt or gears.

In case of direct coupling, try to reduce the axial and radial misalignment which would cause an additional pressure on bearings. This would considerably reduce their life and would cause vibrations. The misalignment can be measured by means of a centesimal comparator. The misalignment limit is equal to 0.03 mm both in radial and axial sense.

In case of belts, make sure that the motor shaft is perfectly parallel to the pulley axis. The pinion and the pulley must be aligned, in order to avoid undesired axial loads on the bearings and heavy wear of the drive belt. The belt tensioning must comply with the manufacturer's instructions and must not cause excessive radial load on the bearing, which would reduce its life.

In case of gears, observe their distance during the motor assembly. If you use helical gears, make sure the axial load does not damage the motor bearing. Check the radial load generated by the gears (especially with large pressure angles), in order to avoid a strong reduction of the bearing fatigue life. When assembling the pinion on the shaft, avoid radial stress to the motor bearing by using adequate tools.

For further information about the calculation of the bearings fatigue life depending on the load and on the rotation speed, please refer to Standard ISO 281.

### 5.4 Connections and LEDs

All connections of servodrive ICOS 3110 are ensured by removable connectors; the following picture shows the connectors position:

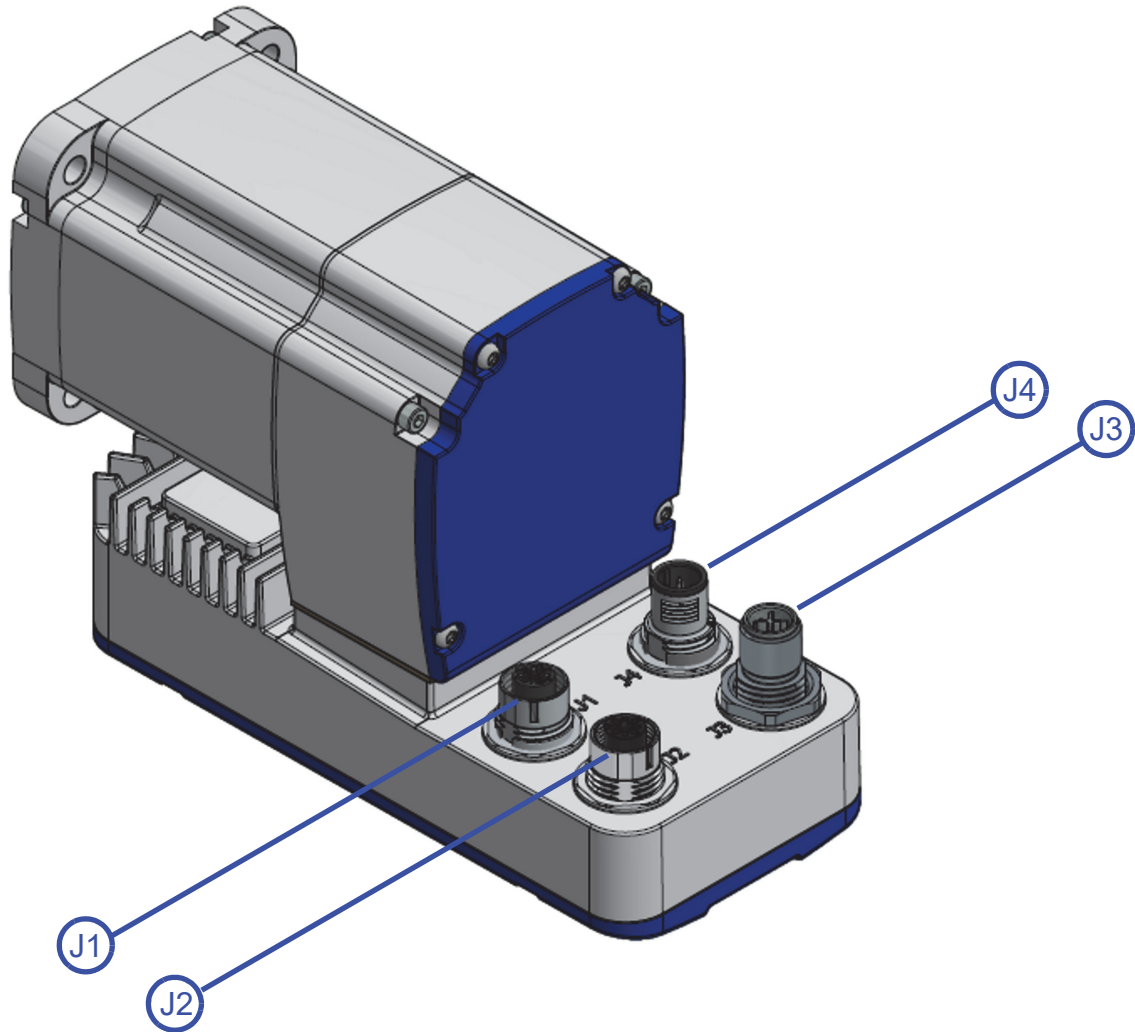

The following table describes the function of each connector:

Connections	
Code	Description
J1	Fieldbus - FixIO
J2	Digital inputs
J3	DC-bus main power supply
J4	24Vdc auxiliary power supply and parking brake input (where provided)

**5.4.1 DC-bus power supply - J3**

These are the connections of the main power supply (DC bus), with corresponding connection of the protection earth (PE/Ground).

**CAUTION**

	<p>Large capacitors inside the device. Risk of Electric Shock; wait at least No. 600 seconds (10 minutes) after disconnecting power. Do not connect or disconnect cable and connectors before that time.</p>
---	--

**ATTENTION**

	<p>Hautes capacités présentes à l'intérieur de l'appareil. Risque de choc électrique; attendez au moins 600 secondes (10 minutes) après la mise hors tension. Les câbles et les connecteurs ne doivent pas être connectés ou déconnectés avant la fin du temps indiqué.</p>
---	---

The following picture shows the connector and the pin configuration:

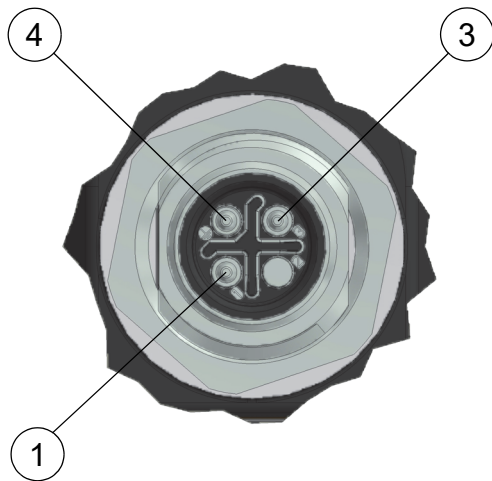

Main power supply	
Pin	Signal
1	B+ (positive)
2	NC
3	B- (negative)
4	PE (Ground)

Connector type: Phoenix Contact SACC-DSI-M12MSS-3P-M16/0,5 PE (1411653) * **	
Features	
Rated voltage	630 V
Rated current	16 A
N. poles	3
Mass resistance	≤ 3 mΩ
Insulation resistance	≥ 100 MΩ
Standards	M12 connector
Contact material	CuZn
Contact surface material	Au
Contact insert material	PA
Ring material	CuZn alloy, nickel
Seal material	FKM
Inflammability class according to UL 94	V0
*= Use 60 °C / 75 °C wires only	
**= Use Copper Conductors only	

The following picture shows the recommended connection scheme:

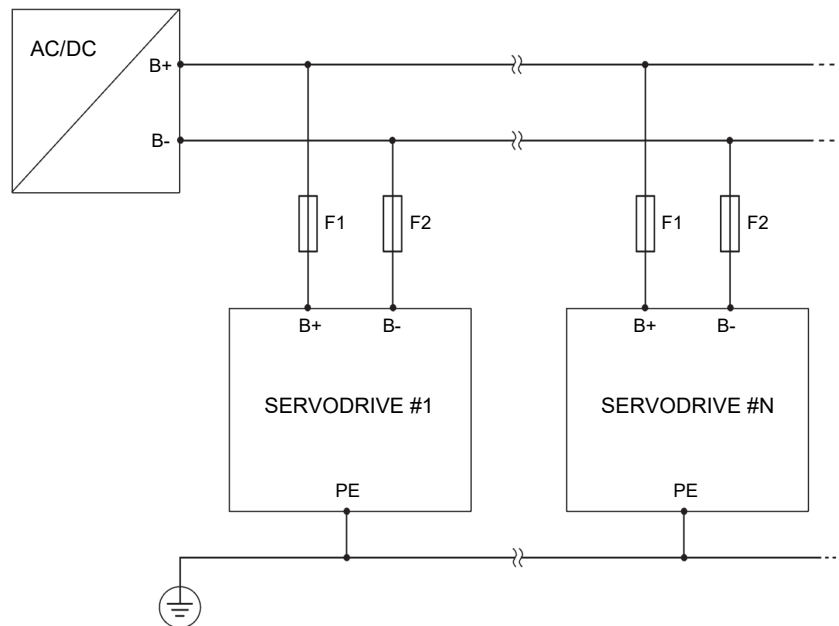

The mains voltage is obtained from the mains power supply through the power supply unit; be careful to the voltage polarity while making the connections.

**CAUTION**

	<p>For safety reasons, the device must always operate with PE (Ground) connection; risk of Electric Shock and/or malfunctions.</p>
---	--

**ATTENTION**

	<p>Pour des raisons de sécurité, l'appareil doit toujours fonctionner avec la connexion PE (Ground) insérée; risque d'électrocution et / ou de dysfonctionnement de l'appareil.</p>
---	---

**CAUTION**

	<p>The servomotor generates high earth leakage current; do not power the servomotor without PE (Ground) connection, to avoid the risk of Electric Shock if you touch metal components (such as the heat sink).</p>
---	--

**ATTENTION**

	<p>Le servomoteur génère un courant de fuite élevé vers la terre; ne pas alimenter le servomoteur sans connecter PE (Ground) pour éviter le risque de choc électrique en touchant des parties métalliques exposées (par exemple, le dissipateur de chaleur).</p>
---	--

5.4.1.1 Conductors and protective devices

5.4.1.1.1 Protection for UL applications

	<p>This device is Suitable For Use On A Circuit Capable Of Delivering Not More Than 5000 Arms Symmetrical Amperes, 325Vdc Maximum when protected by semiconductor fuse model FR10GR69V20 by Mersen.</p>
---	---

5.4.1.1.2 Protection for other applications

The conductors cross section for wiring the connector must be equal to 1.5 mm<sup>2</sup>/ 16 AWG.

	<p>The use of conductors with lower section than the recommended value might cause fire or damage to people or property.</p>
---	--

The device and the supply conductors must be protected against overload and short-circuits, by means of protective devices, able to interrupt continuous currents.

**CAUTION**

	<p>The use of an inadequate overcurrent protection device could cause a failure to intervene, with danger for people and things. Furthermore, spurious protection interventions may occur.</p>
---	--

**ATTENTION.**

	<p>L'utilisation d'un dispositif de protection contre les surintensités inadéquat pourrait entraîner une absence d'intervention et entraîner des risques pour les personnes et les objets. De plus, des interventions de protection parasites peuvent se produire.</p>
---	--

For an adequate protection of the device and of the conductors (according to IEC 60204-1), it is recommended to use fuses connected in series to both power supply lines. The protective conductor (PE/ Ground) must never be sectioned.

The following table indicates the recommended fuse features:

<b>Class</b>	gPV (IEC 60269-6)
<b>Size</b>	10x38 mm (13/32" x 1 1/2")
<b>Rated current</b>	12 A
<b>Operating voltage</b>	500V min.

The following table lists some adequate fuses:

<b>Manufacturer</b>	<b>Part-number</b>
Littelfuse	0SPF012.T
Littelfuse	KLKD012.T
Bussmann	PV-12A10F
Italweber	1463012
Mersen (Ferraz Shawmut)	HP6M12
Schrack	ISV10012

The breaking capacity of the fuse must not be lower than the maximum short-circuit current at the installation point; the short-circuit current must be limited to max. 5 kA at the servodrive input.

Should the servodrive be included in a machine, refer to the Standard EN 60204-1 for further details about its size.

The servodrive is not directly connected to the main power supply and does not integrate any filter to reduce emissions; the filtering must be ensured by the power supply unit and/or by an adequately sized filter. The acceptable levels of emission depend on the environmental and operating conditions (number of servodrives, cable length, current values, rules in force); the user is responsible for the choice of the filter.



5.4.2 FlxIO field bus - J1

	<p>Refer to the FlxIO bus integration and FlxMod system DK400076 manual for the correct definition of the connection topology of the FlxIO bus.</p>
---	---

The servomotor is equipped with an interface for the proprietary field bus FlxIO; it is based on an isolated RS485 electrical interface, and allows reliable real-time control of complex applications.

The connection is made through the J1 connector on the front panel; the illustration below shows its pinout.

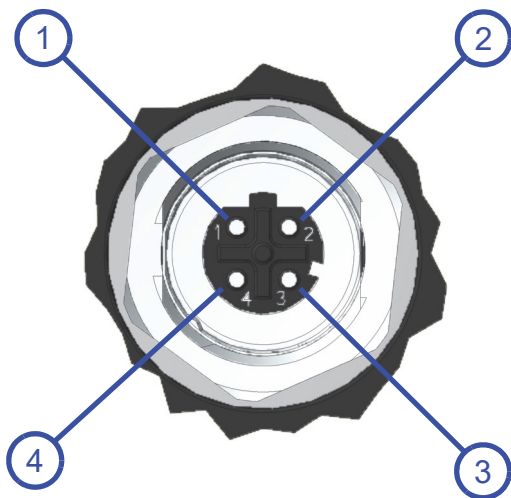

FlxIO field bus	
Pin	RS485 signal
1	DATA+
2	GND
3	DATA-
4	GND

Connector type: Phoenix Contact SACC-DSI-FSD-4CON-L180 SCO (1551503) * **	
Features	
Rated voltage	250 V
Rated current	4 A
N. poles	4
Standards	M12 connector IEC 61076-2-101
Degree of protection	IP67
Contact material	CuZn
Contact surface material	Au
Contact insert material	PA 66
Seal material	NBR
Screw material	CuZn alloy, nickel

Inflammability class according to UL 94	V0
<p>*= Use 60 °C / 75 °C wires only</p> <p>**= Use Copper Conductors only</p>	

The connections must be made with cables suitable for RS485 serial lines (shielded and with at least one twisted pair with 120Ω impedance for the differential signals).

To connect in cascade several ICOS 3110 or other FxIO bus devices equipped with the same type of connector (M12 D-coding), it is necessary to use a branch wiring with Y configuration (split; 1xM 2xF). For this purpose the use of the Smitec EC100379 cable is recommended.

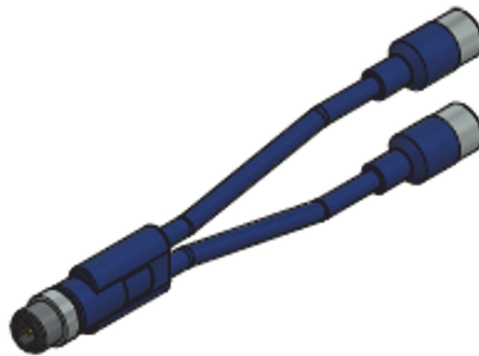

EC100379

To avoid reflections, which are harmful to the quality of the signal especially in the case of long stretches, it is necessary to connect a 120Ω termination resistor at the end of the line. To facilitate this termination, the resistor is integrated in the KF131326 connector, to be connected to the free connector of the branch wiring or in any case to the last FxIO device connected in cascade. Head-of-line termination is usually integrated into the master device. The ground connection (GND), although not essential for functional reasons, is nonetheless recommended to improve the immunity of the system against EMC disturbances.

**5.4.3 Auxiliary power supply 24V - J4**

This is the connector for connecting the 24V auxiliary power supply, which is used to power the control section of the device; the connector pinout is shown below:

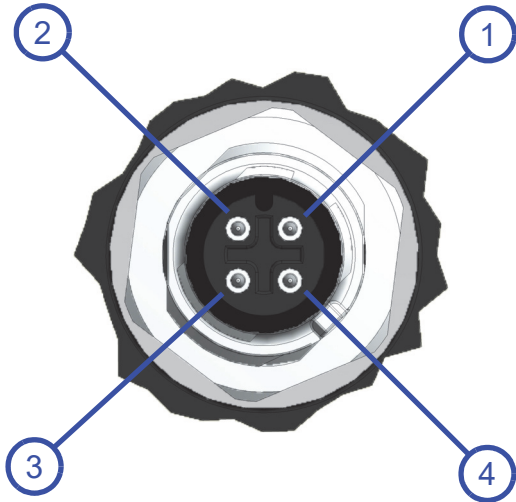

Auxiliary power supplies	
Pin	Signal
1	+ Parking brake
2	- Parking brake
3	GND
4	24V

Connector type: Phoenix Contact SACC-DSI-MS-4CON-L180 SCO - 1553459 * **	
Features	
Rated voltage	250 V
Rated current	4 A
N. poles	4
Mass resistance	≤ 3 mΩ
Insulation resistance	≥ 100 MΩ
Standards	M12 connector IEC 61076-2-101
Contact material	CuZn
Contact surface material	Au
Contact insert material	PA 66
Ring material	CuZn alloy, nickel
Seal material	FKM
*= Use 60 °C / 75 °C wires only	
**= Use Copper Conductors only	

	<p>Check the voltage polarity before connecting the servodrive, in order to avoid damages to the device.</p>
	<p>The 24V cables must be protected against over-currents. Some types of power supply units function as a protection. For further details about the protections size, refer to the IEC 60204-1.</p>

The auxiliary power supply voltage must be stable and contained within the limits of the servomotor (refer to the specific paragraph). If these voltages are outside the prescribed limits, the unit could be damaged.

	<p>For safety reasons, these power supply must be supplied by a PELV power supply unit, with ground terminal connected to earth (preferably at one point only, in order to avoid ground loops).</p>
---	---

**5.4.4 Digital inputs and power supply with 24V output - J2**

This is the connector for connecting the digital inputs and for powering any external sensors; the pinout of the connector is shown below:

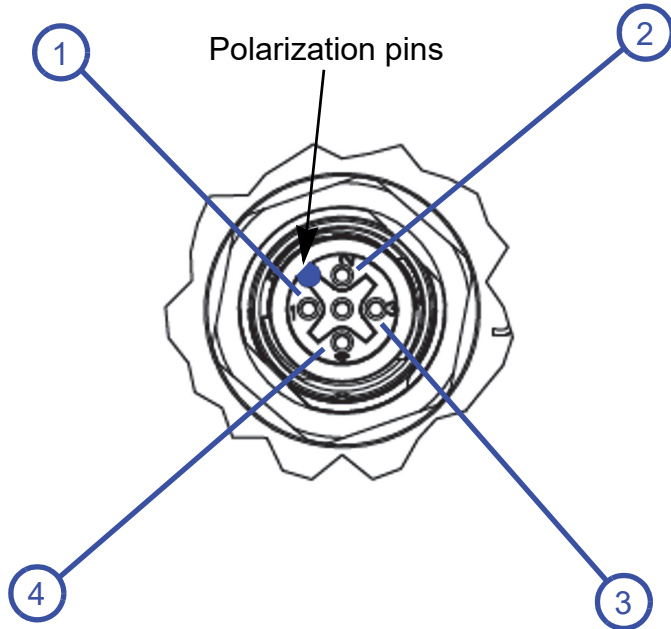

Digital inputs and Vs	
Pin	Signal
1	24V (Vs)
2	Digital input 1
3	GND
4	Digital input 2

Note: pin 1 of the connector (Vs 24V) is to be used exclusively to power any sensors or actuators external to the drive; the maximum current that can be drawn is 500mA.

Connector type: Phoenix Contact SACC-DSI-FS-4CON-L180 SCO - 1553462 * **	
Features	
Nominal tension	250 V
Rated current	4 A
N. poles	4
Mass resistivity	≤ 3 mΩ
Insulation resistance	≥ 100 MΩ
Standards/Regulations	Connector M12 IEC 61076-2-101
Contact material	CuZn
Contact surface material	Au
Contact holder insert material	PA 6.6
Ferrule material	Zinc die cast, nickel plated

Gasket material	NBR
*= Use 60 °C / 75 °C wires only **= Use Copper Conductors only	

**5.4.4.1 24V digital inputs**

The servomotor is equipped with two general purpose 24V digital inputs. The typical use of these inputs consists in the acquisition of sensors with digital output, very common in the industrial field (example: photocells, limit switches, etc...).

The following picture shows an example of how a sensor is connected; in most applications, an ordinary unshielded cable can be used for the wiring.

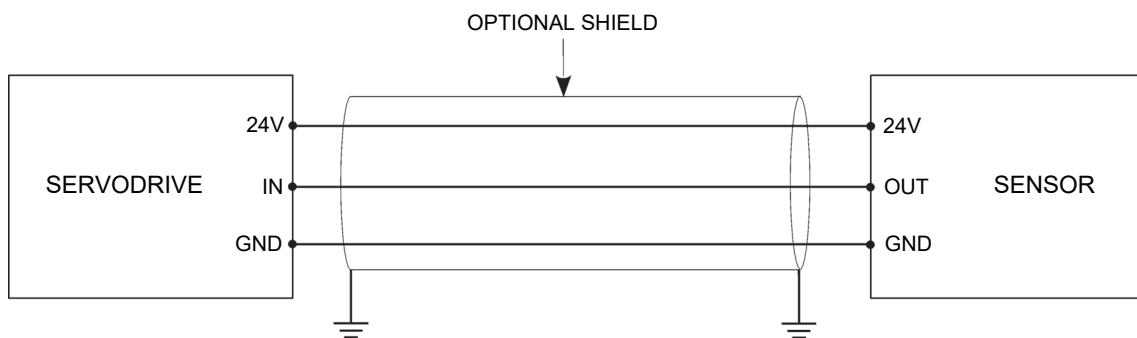

However, if the operating environment is affected by significant electrical noise or the distances to be covered are significant, it might be necessary to use a shielded cable. In this case, the shield must be connected to the connector shell of the servodrive, with low RF impedance; the shield is totally ineffective if it is left floating. In most cases, it can be useful to connect the shield to earth on the other end of the cable; this is to be avoided if it causes ground loops due to different potentials between the shielded cable ends. Therefore, a correct connection must be determined according to the application.

Signal quality may be further improved by keeping the cables as far away as possible from noise sources such as power cables, inverters, power supply units, relays, etc...

	<p>Check the sensor polarity before connection; inverted polarity can damage the sensor and/or the servodrive.</p>
--	--

**5.4.5 LEDs**

The device has 3 LED indicators, marked with the STS label, which inform the user about the state of the field bus (FlxIO), of the supply lines and of the operating condition.

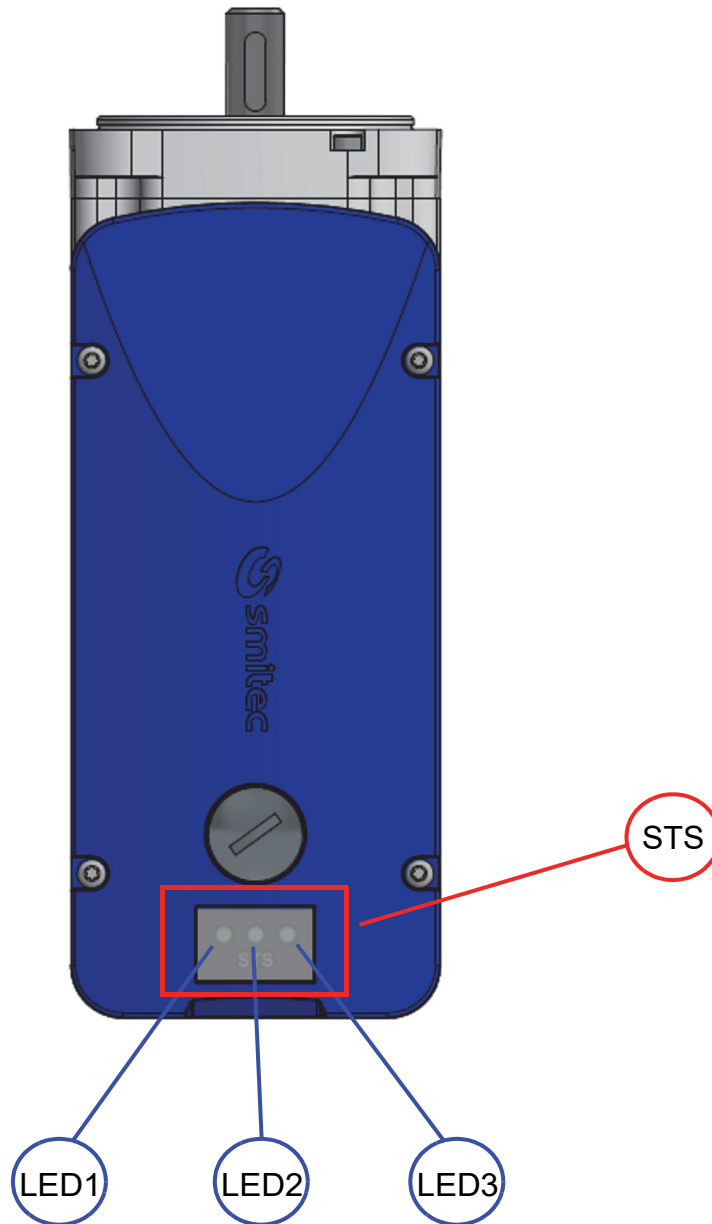

**5.4.5.1 References signaling LEDs (STS)**

Name	Function
LED1	Status of the 24V power line (green LED)
LED2	Fieldbus status (green LED)
LED3	Fieldbus status (red LED)

**5.4.5.2 LED1 behavior**

LED1 (green)	Meaning
ON	24V I/O supply voltage present
OFF	24V I/O supply voltage absent

**5.4.5.3 LED2 and LED3 behavior**

They take on the following meaning, in accordance with the FlixIO standard, based on their switching on and off and the frequency with which they flash:

LED2 (green)	LED3 (red)	Meaning
Flash 1Hz	ON	Controller firmware update dedicated to FlixIO communication
ON or OFF	ON	Controller hardware fault dedicated to FlixIO communication
Flash 1Hz	OFF	Initialization of FlixIO communication in progress
Flash 4Hz	OFF	FlixIO communication in error
ON	OFF	Indicates whether the communication of the master FlixIO device is active or not (bootloader phase)

In the event of an error, the diagnostics is returned via the FlixIO bus; so if you need to know the type of error that occurred, you will need to query the system via the FlixIO bus.



5.4.6 Installation criteria for UL certification

	<p>Cord connected device are for use only in NFPA 79 applications.</p>
	<p>Integral solid state short circuit protection does not provide branch circuit protection. Branch circuit protection must be provided in accordance with the Manufacturer Instructions, National Electrical Code and any additional local codes.</p>
	<p>The drive does not provide Motor Overload protection. External or remote Motor Overload protection shall be provided in the end-use applications.</p>
	<p>Motor over-temperature sensing function is provided connecting the UL certified sensor positioned in to the motor, to the control board of the drive. For ICOS Series this connection is internal to the enclosure and was made by the manufacturer.</p>

## 5.5 Addressing

Like all slave devices with FlxIO field bus, the ICOS servodrives need to be addressed for a correct data exchange with the master device. Each slave device must have its own address; two devices with the same address cause communication problems and might cause uncontrolled behaviour of the system. It is possible to address up to 15 devices in the same bus.

The addressing of servodrives can be either manual or automatic; you can find further details in the following paragraphs.

For further details about the FlxIO field bus operation and connection topologies, refer to the specific documentation.

### 5.5.1 Manual addressing

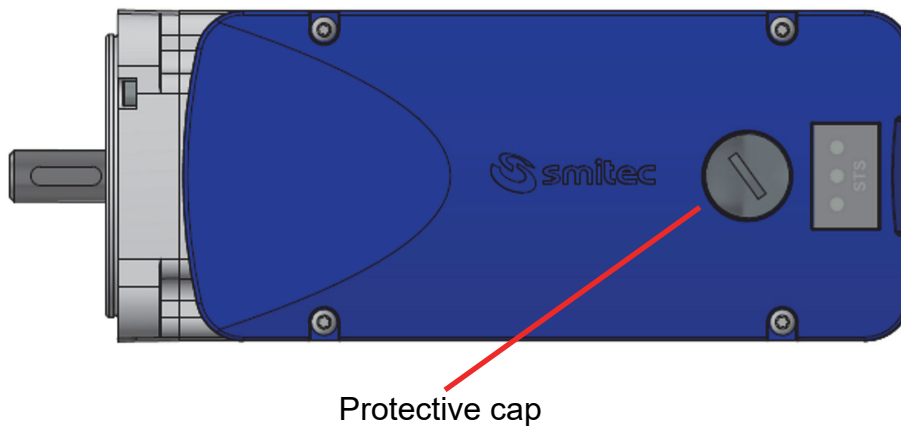

In this mode, the servomotor address must be set using the appropriate rotary switch that is easily accessible by unscrewing the cap shown in the image above.

The switch can be set to 16 different positions, from 0 to F (hexadecimal notation), using a small flat blade screwdriver.

After setting the address, screw the cap to ensure the degree of protection (IP) of the device.

The following table shows the correspondence between decimal values and hexadecimal values:

<b>Decimal</b>	0	1	2	3	4	5	6	7	8	9	10	11	12	13	14	15
<b>Hexadecimal</b>	0	1	2	3	4	5	6	7	8	9	A	B	C	D	E	F

Address 0 must never be used.

Since the address is acquired by the servodrive only after supplying auxiliary voltage, the setting must be carried out before powering it, otherwise the variation is ignored until the servodrive is started again.

	<p>Make sure the address is correct before powering the devices, otherwise the system behaviour may be uncontrolled; danger to people and/or properties.</p>
	<p>Once you removed the cap, be very careful that nothing falls inside the device, in order to avoid damages or electrical shocks.</p>

## 6 Firmware upgrade

Following significant improvements or additional functionalities, the servodrive ICOS 3110 can be updated with a more recent firmware version.

This operation can be carried out through FxIO field bus (remote programming); if the master device recognizes that the servodrive is programmed with a different FW version as compared to the version loaded in the memory, it automatically re-programmes it. The procedure can be carried out when the devices are started. It is not possible to upgrade a device directly.

To upgrade the servodrive, it is necessary to upgrade the FW of the master device, which will then upgrade the slaves.

## 7 Storage

The device and its components can be stored in their original packaging and always in a covered place, even if they are packed. Protect the device against dust and atmospheric agents.

Do not stack more than 10 power supply units, in order to avoid overstretching the package and/or device.

The storage temperature should be within  $-25^{\circ}$  and  $+55^{\circ}\text{C}$ .

## 8 Maintenance

SMITEC S.p.A. does not recommend any ordinary maintenance of the servodrive ICOS 3110; it is not allowed to disassemble any component, because it might compromise the safety degree of the device.

Any repairs must be performed exclusively by SMITEC S.p.A.

## 9 Disposal and demolition

The disposal of this device must be carried out according to the laws in force in the country where it was installed. Should the disposal be partial (frame, heat sink, electronic boards), separate the components made of plastic from the components made of aluminium, etc. Their disposal must be in compliance with the law in force in the country where the device was installed.

## 10 Analytical index

<b>A</b>		<b>S</b>	
Accessories.....	13	Shaft diameter.....	11
Altitude.....	11	Storage temperature.....	11
Assembly.....	6		
Automatic addressing.....	35	<b>T</b>	
Auxiliary power supply.....	27	Torque transmission.....	18
<b>D</b>		<b>W</b>	
DC power supply.....	20	Weight.....	14
Degree of protection.....	11		
Delivered torque.....	10		
Digital inputs.....	30		
Digital outputs.....	12		
<b>E</b>			
Electrocution.....	7		
Electromagnetic field.....	8		
<b>F</b>			
Fastening.....	17		
Field bus.....	25		
FLxIO.....	34		
<b>H</b>			
Handling.....	6		
<b>I</b>			
I/O.....	29		
Individual protections.....	5		
<b>J</b>			
J1.....	19, 20		
J4.....	19, 25		
J7.....	29		
<b>M</b>			
Manual addressing.....	34		
<b>O</b>			
Operating temperature.....	11		
<b>P</b>			
Positioning.....	15		
Power supply.....	12		
Preliminary operations.....	15		
<b>R</b>			
Rotation speed.....	10		
Rotor moment of inertia.....	10		