

CPL ST/3N/SD/3D

SERCOS III and Modbus TCP fieldbus coupler

Datasheet

Description

SERCOS III and Modbus TCP fieldbus coupler for FLXMOD system modules.

- Two ethernet fieldbus ports with RJ45 standard connectors
- Easy address setting by rotary switches on front panel
- Three FLXIO™ ports
- Status and diagnostic LEDs

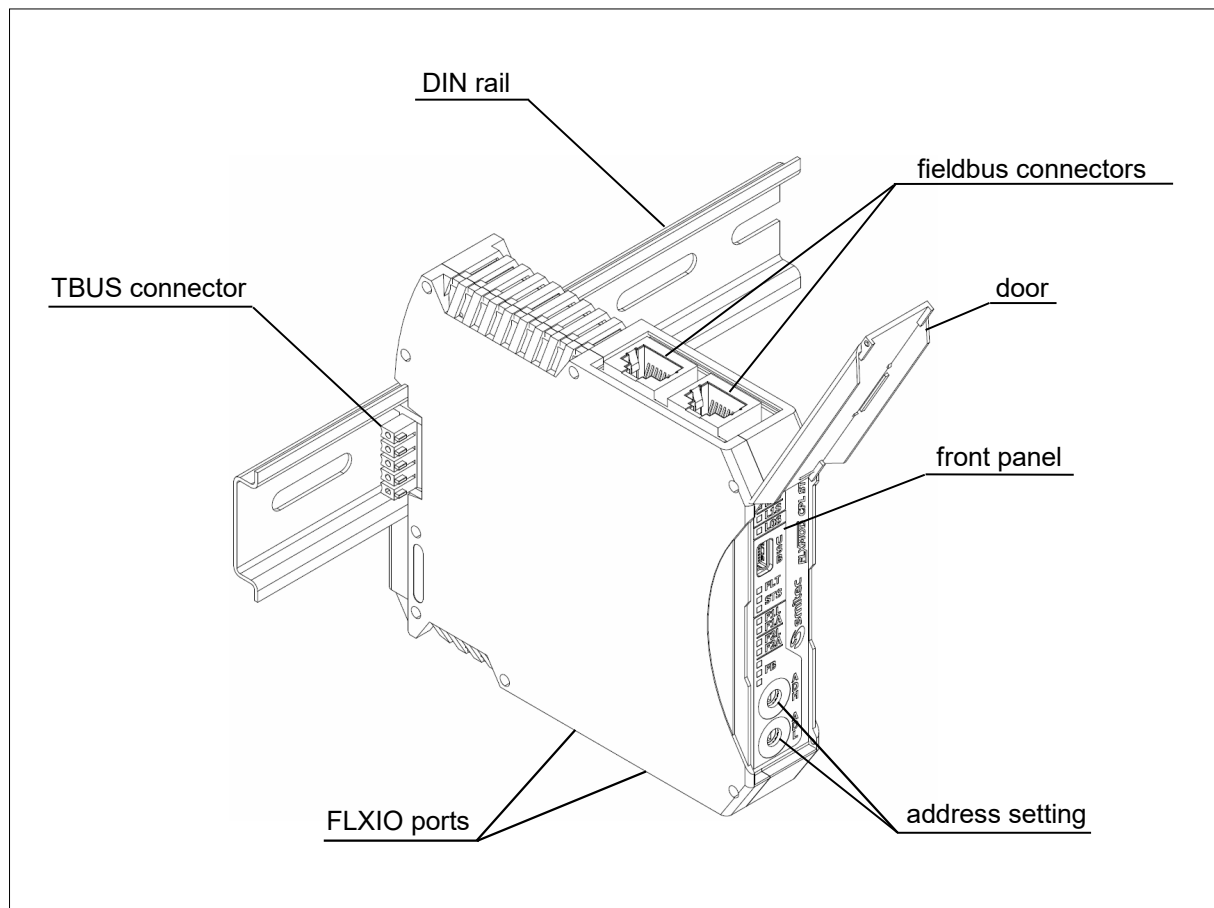

Ordering informations

Products	SMITEC part number
FLXMOD CPL ST - Sercos III single node and TCP fieldbus coupler with TBUS connector	KZ010449
FLXMOD CPL 3N - Sercos III triple node and TCP fieldbus coupler with TBUS connector	KZ010498
FLXMOD CPL SD - Sercos III single node and TCP fieldbus coupler with TBUS connector and advanced diagnostic support	KZ010577
FLXMOD CPL 3D - Sercos III triple node and TCP fieldbus coupler with TBUS connector and advanced diagnostic support	KZ010578

Accessories	SMITEC part number
TBUS connector (Phoenix Contact p/n 2713722)	KF101034
WinMicro programming software	KW050111
USB programming and diagnostic cable	EC100213

Documentation	SMITEC part number
Installing instructions	DK400042
Datasheet for CPL ST/3N/SD/3D	DK400172
FLXIO and FLXMOD system integration manual	DK400076

Technical data

General data	
Housing dimensions (width x height x depth)	22.5 mm x 99.0 mm x 114.5 mm
Weight	122 g (without connectors), 126 g (with TBUS connector)
Functional earth connection	To the DIN rail by spring contact
Module state visual indicators	Status and diagnostic LEDs on front panel

Environment data	
Permissible operating temperature	+5° to +55°C
Permissible storage and transport temperature	-25° to +85°C
Permissible humidity	10% to 95%, not condensing
Permissible air pressure (operation)	80 to 106 kPa (up to 2000 m above sea level)
Permissible air pressure (storage and transport)	70 to 106 kPa (up to 3000 m above sea level)
Degree of protection (CE)	IP20 according to IEC 60529
Degree of protection (UL)	Open Type
Overvoltage category	II
Pollution degree	2
Means of protection (UL)	Class III SELV power supply

Power supply	
Module power supply	5 VDC and 24 VDC from local bus
Power load from local bus at 5V DC	Approx. 2W
Power load from local bus at 24V DC	None
Total power dissipation	Approx. 2W

Fieldbus interface	
Fieldbus type	SERCOS III and Modbus TCP (Ethernet based)
Module address setting	By two rotary switches on front panel
Connectors and cables for fieldbus	Ethernet CAT5E shielded cables and RJ45 connectors
Transmission speed	100 Mbps

Local bus interface	
Local bus type	Proprietary FLXIO™
Number of bus ports	Three (one with backplane TBUS connectors and two with Ethernet RJ45 connectors)
Transmission speed	1.25 Mbps
Max. number of I/O slaves	15 for each FLXIO™ port, 45 total

Firmware updating	
Programming port	USB mini B standard connector on front panel
Programming tool	Standard PC and WinMicro utility

Connections

The module (see illustration) has six connectors: two for the fieldbus interface on the upper side, two for the local FLXIO™ buses on the lower side and the TBUS connector on the backplane for the routing of the third FLXIO™ bus. In addition to these, an USB connector is located on the front panel for programming and diagnostic purposes.

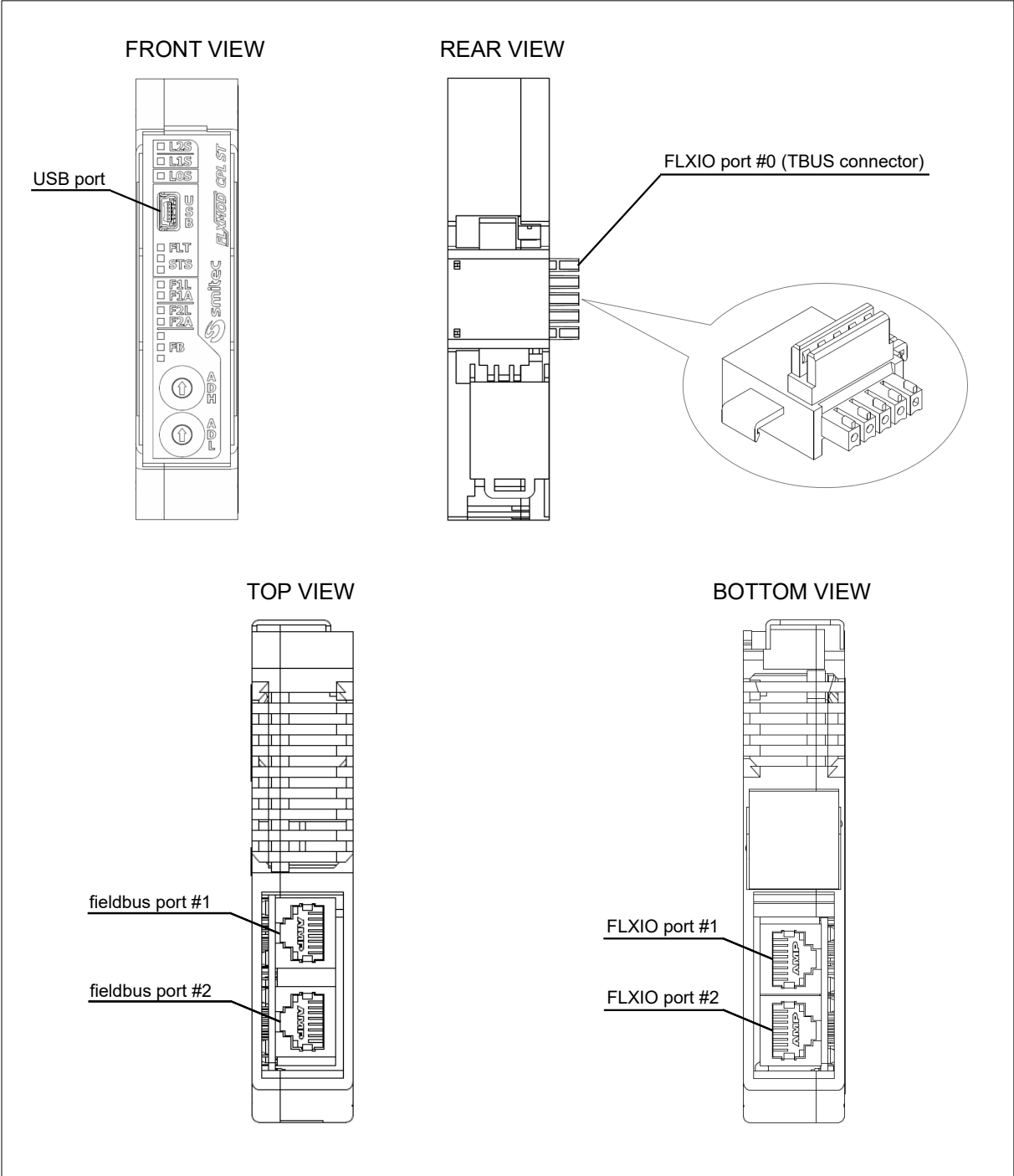

They allow easy “plug and play” of the module, and also a fast replacement of a faulty unit. The power supplies for the module are derived from the TBUS connector; there is no provision for an external connector.

The topology of the SERCOS III and modbus TCP network must be in accordance with the relevant standards.

The wiring should be done using standard CAT 5E Ethernet cable and RJ45 connectors.



Warning: To ensure conformance with EMC directive 2014/30/UE, the length of the cables must not exceed 30 m!



Warning: If the equipment is used in a manner not specified by the manufacturer, the protection provided by the equipment may be impaired

Address setting

Each of the the slaves put in a fieldbus network must have an unambiguous address, so it must be easily set up on the field. This module is provided with two rotary switches fitted on the front panel, each one with 16 different positions (from 0 to F, using hexadecimal notation); they are easily set using a small bladed screwdriver (a small click is heard when changing the position of the rotor). Being the address composed by one byte, the four most significant bits are set by the ADH switch and the least significant bits are set by the ADL switch.

Because the address is read only once at the startup, the user should set it before powering the module; no change is observed until the module has been newly restarted.

Acting the coupler as a slave for the fieldbus network and as a master for the following FLXIO™ modules, the user should also configure these ones according to the FLXIO and FLXMOD system integration manual.

Diagnostic and status indicators

Each module is provided with a series of LED lamps on the front panel (see illustration), that indicates the status of the unit, the logic state of every output and a possible diagnostic warning. For the sake of clarity, different lamp colours are employed.

L0S, **L1S** and **L2S** green LED lamps indicate the corresponding FLXIO™ bus port status. Their behaviour is described in the following table.

LxS LED	Status
Slow blink (1Hz)	Bus initialization
Off	No communication
On	Regular communication
Fast blink (5Hz)	Communication error

At system power-up or after system reset the CPL ST/3N/SD/3D module starts the initialization phase where it searches for devices connected to the three FLXIO™ bus ports and their corresponding LEDs blink slowly.

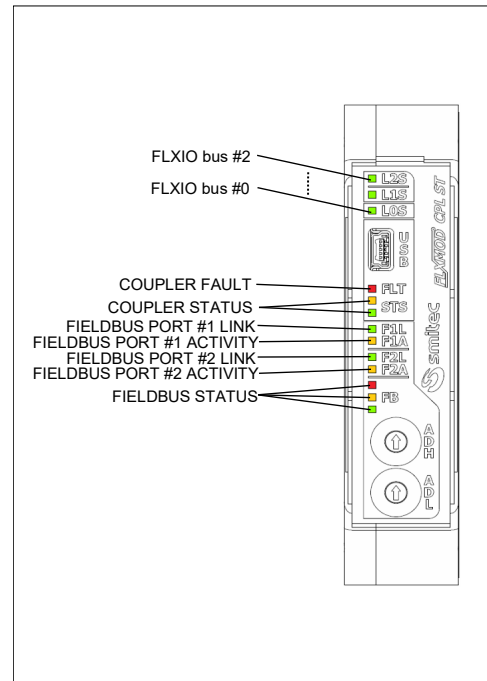

When this phase is complete, if one FLXIO™ port have not functional modules connected, the corresponding LED switches to off state; instead, if one FLXIO™ port have one or more functional modules connected, the corresponding LED switches to on state.

In case of communication error during initialization phase or during normal operation (e.g. faulty module, faulty cable, etc.) on one FLXIO™ port, the corresponding LED switches to fast blink state.

FLT (red) and **STS** (orange and green) LEDs indicate the CPL ST/3N/SD/3D functional status; due to numerous possible functional status a coded LEDs blink system is employed. Regular operation only (no errors) have the STS green LED fixed to on; in all other cases a numeric error is displayed by a contemporaneous orange and green STS LEDs short flash followed by a pulse sequence on orange LED representing tens of error number and, at last, followed by a pulse sequence on green LED representing units of error number. The sum of tens and units gives the whole error number that are summarized in the following table. The described LEDs blink sequence is repeated until the error persists.

FLT LED	STS LEDs code	Status
Off	15	EEPROM checksum error
On	1	Microcontroller RAM test error

FLT LED	STS LEDs code	Status
On	2	Microcontroller flash memory test error
On	3	System RAM test error
On	4	System flash memory test error
On	5	SW/HW CPU error
On	6	SW/HW CPU error
On	7	Unexpected HW NMI
On	8	SW/HW system interrupts error
On	9	SW/HW CPU error
On	10	Unexpected SW interrupt
On	11	Unexpected HW MI
On	12	OS task creation error
On	13	OS resources allocation error
On	14	Module overtemperature (>85°C) – Suppressed from firmware version 1.30
On	15	Voltage out of range (24VBus>30V or 24VBus<19.3V)
On	16	FPGA HW programming error

F1L and **F2L** green LEDs when lighted indicate the detection of link (connection to other functional ethernet device) on the corresponding fieldbus port.











F1A and **F2A** orange LEDs when blink indicate the activity (reception or transmission of ethernet data packet) on the corresponding fieldbus port.

The three **FB** LEDs (red, orange and green) display the general status of fieldbus communication.

The CPL ST/3N/SD/3D is set to manage Modbus TCP communication until it is in NRT phase (no Sercos III communication); when the Sercos III phase goes up, the Modbus TCP communication is disabled.

In Modbus TCP communication mode the red FB LED is always off, the green FB LED is lighted when a client has required a TCP/IP service to the module, the orange FB LED blinks when happens a valid Modbus TCP communication.

In Sercos III communication mode the three FB LEDs take the behaviour described in the Sercos III specification version 1.3-1.2 and it is reported in the following table.

Pattern	Color	Description	Priority	Comment
#1	dark	NRT-Mode	0	no sercos communication
#2	orange	CP0	0	communication phase 0 is active
#3		CP1	0	communication phase 1 is active
#4		CP2	0	communication phase 2 is active
#5		CP3	0	communication phase 3 is active
#6	green	CP4	0	communication phase 4 is active
#7		HP0	1	device is in hot-plug phase 0
#8		HP1	1	device is in hot-plug phase 1
#9		HP2	1	device is in hot-plug phase 2
#10		Fast forward ⇒ Loopback	2	RT-state has changed from fast-forward to loopback
#11		application error	3	see GDP & FSP Status codes class error
#12		MST losses ≥ (S-0-1003/2)	4	as long as the communication warning (S-DEV.Bit15) in the Device Status is present, at least 2 sec.
#13	red	communication error	5	see SCP Status codes class error
#14		Identification	6	(C-DEV.Bit 15 in the Device Control) used for address allocation, configuration error or other identification purposes
#15		Watchdog error	7	

Note: the time division for LED flashing is 250 ms (4 Hz).

Firmware update

The user can update the firmware connecting the module to a personal computer by the USB port located on the front panel. The operation is easily done using WinMicro utility and loading the new programming file.

During normal operation of the devices, the USB cable should be disconnected from the unit, or the system might pick up some electromagnetic interferences, leading to incorrect operation of the device.

To carry out this operation you need a PC running Windows XP or later OS with a free USB port. Smittec proprietary software Winmicro and the drivers for the USB port of this device must be already installed. Refer to the instructions included in the installation file.

1. Connect the mini-B connector of the USB cable (type A->mini-B) to this device; it doesn't need to be switched off.
2. Connect the USB cable – side A – to a free USB port
3. If turned off, switch on this device
4. Start Smittec Winmicro software

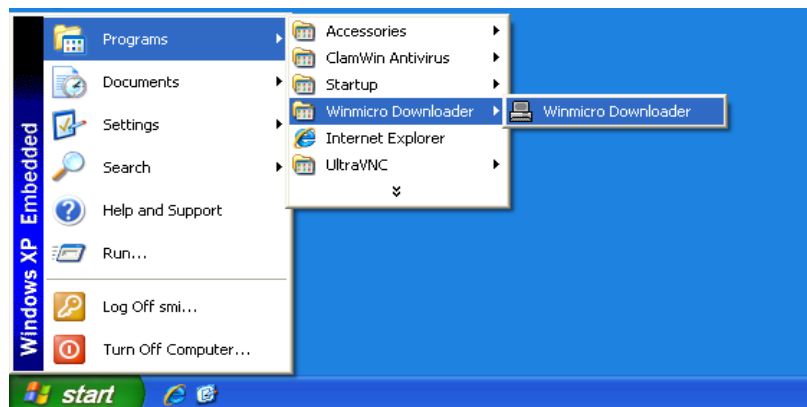

5. Once started the following window will pop up

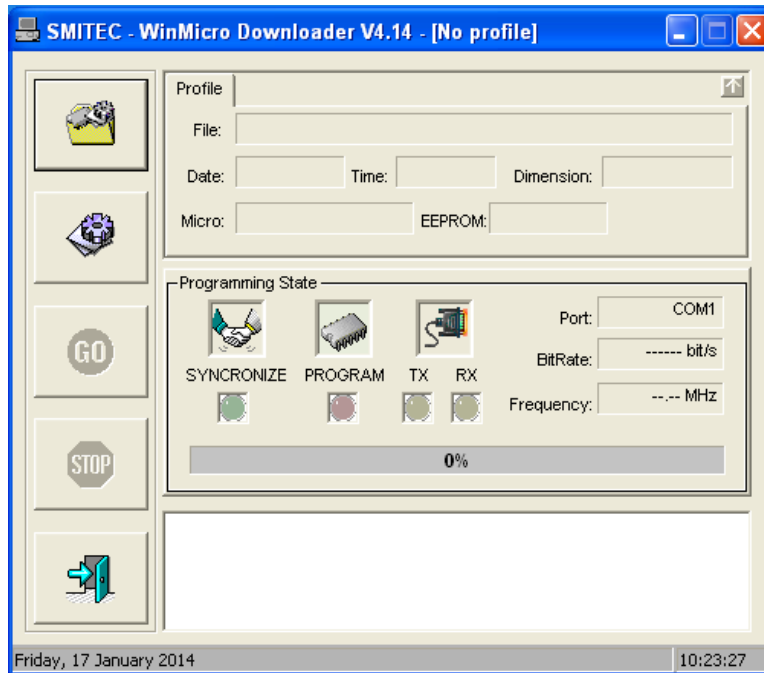

6. Open the program menu clicking on the top left icon.

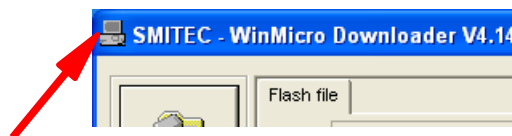

7. Unflag the option “Enable Profiler”



8. Click on the “Settings” button



-
9. The Settings window will open: set the serial port number you will use for the programming (the USB port of this device is recognized by Windows as serial port); as a rule it's the higher COM number available.

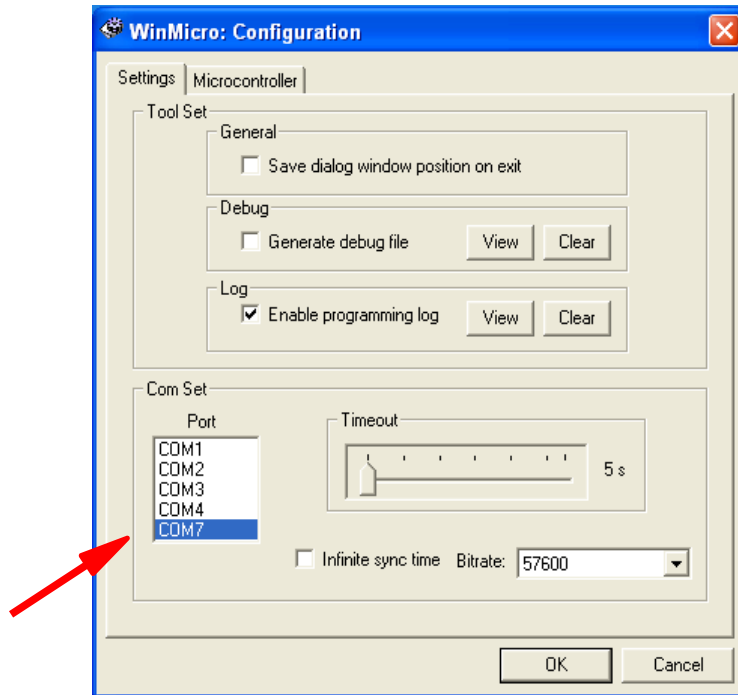

-
- Switch to Microcontroller window and set the microcontroller type, which in this device is SH7211F

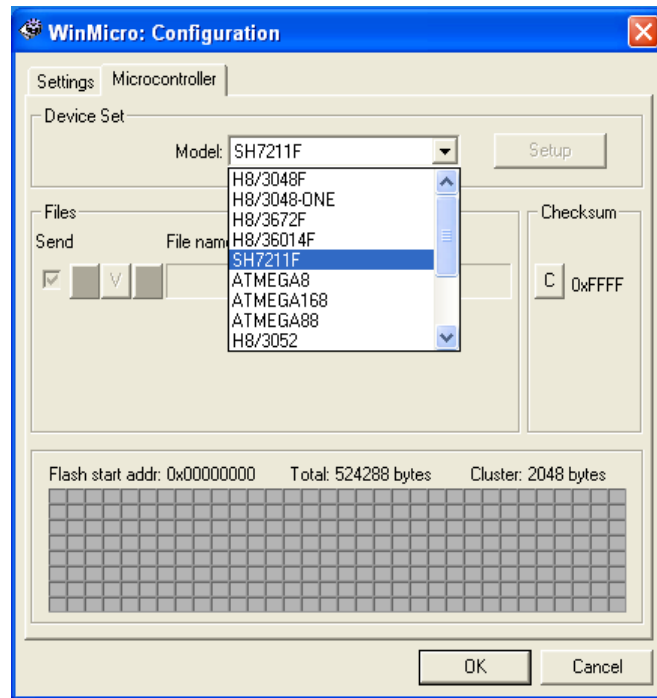

- Click on the OK button
- Click on the button in the main window



13. The window for the selection of the file for the firmware update will pop up: make sure you select the correct file

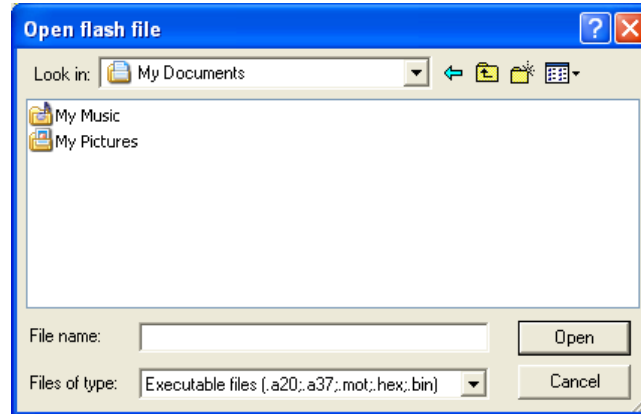

14. Once the file has been uploaded, the main Winmicro window will feature some info on the file and on the selected controller; if this device is switched on, the USB cable is properly connected to the PC and to the module, and the selected port is correct, the USB symbol will pop up beside the word “Port”.

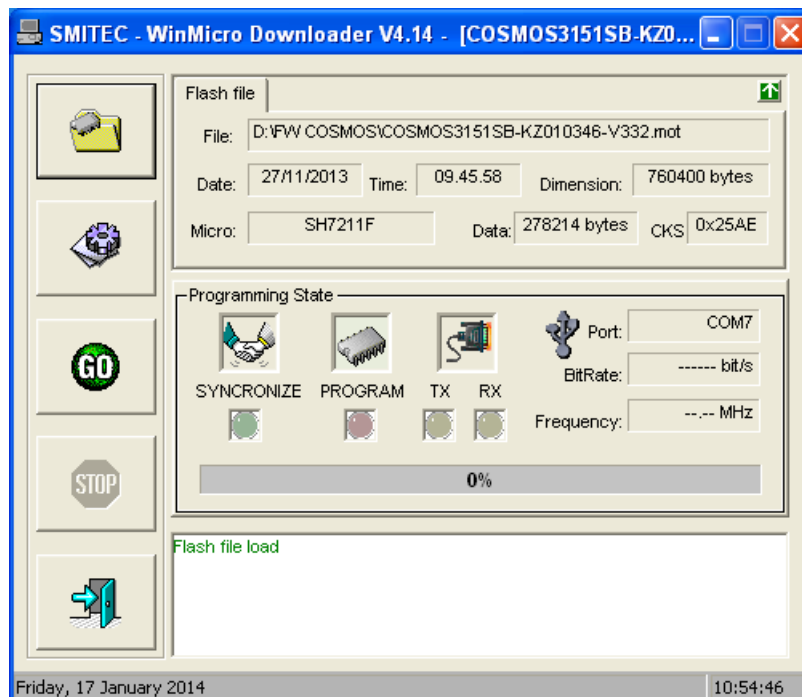

15. Click on the GO button to start programming



16. During programming, status messages will pop up in the lower window and the progress index will proceed

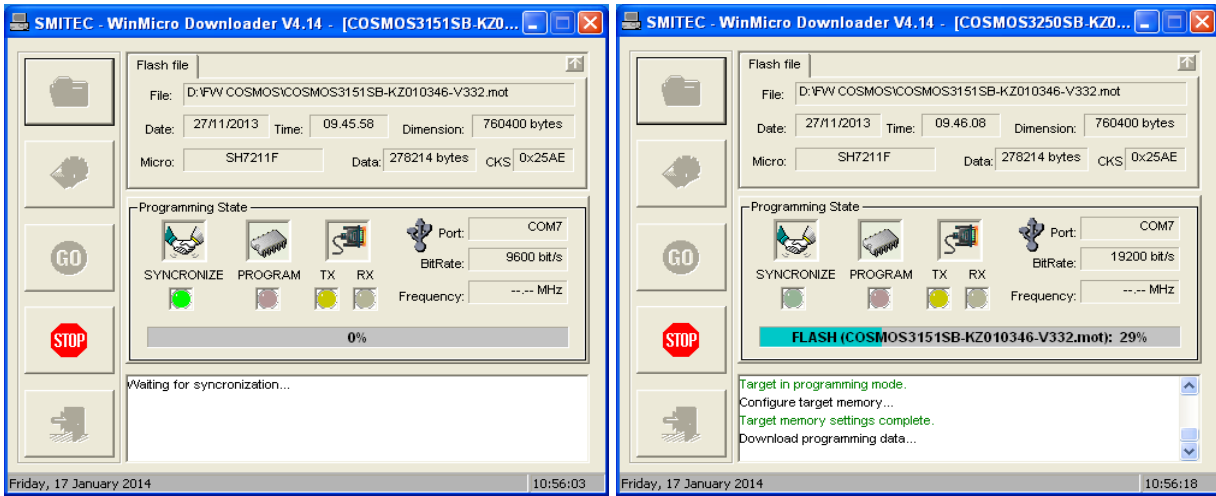

17. At the end of programming the lower window will notify the operation success and the time employed.

18. In case of failure with message “Synchronization Error”, make sure that the microcontroller type, the selected file and port number are correct.

19. Once the update has been completed, exit the program by clicking on the following button

