



## Helcon 10XX

### Heating Lamp Controller

Module for the control of IR heating lamps. Designed for challenging applications on modern machinery, it offers extraordinary flexibility thanks to reliable real-time buses, different lamp power on algorithms, powerful diagnostic and auxiliary functions like power and energy calculation. Designed also for an easy spare parts management, it offers the possibility to substitute the power on electronics of each lamp channel. Available with proprietary FLXIO™ interface for demanding real-time applications with the use of Sercos III™ and Modbus TCP gateways.

## Technical specifications

Housing material	Painted Steel
Degree of protection	IP65
Lamp channels	8-10
Lamp nominal current	7.5A <sub>RMS</sub>
Lamp Power on	Zero Crossing
Diagnostics	Interrupted Load, Overload, Overtemperature
Auxiliary functions	Current measurement, Power and energy calculation
Maintenance	Single channel power on electronics easy substitution
Bus interface	Isolated proprietary FLXIO™ SERCOS III™ and Modbus TCP gateway available
Power supply connection	Harting HAN 100 connector or equivalent
Lamps connection	1.5mt multipolar cable with HAN32 or equivalent connector
Vaux connection	2 M12 cod. A connectors with daisychain
FLXIO connection	2 M12 cod. D connectors with daisychain
Electrical specifications	Main power supply: 360V <sub>AC</sub> ±504V <sub>AC</sub> 2ph 50/60Hz Auxiliary power supply: 24V <sub>DC</sub> -15%±10%
Environmental specifications	Operating temperature from+0°C to +50°C Relative humidity from 5% to 85% (non condensing)

## Dimensions

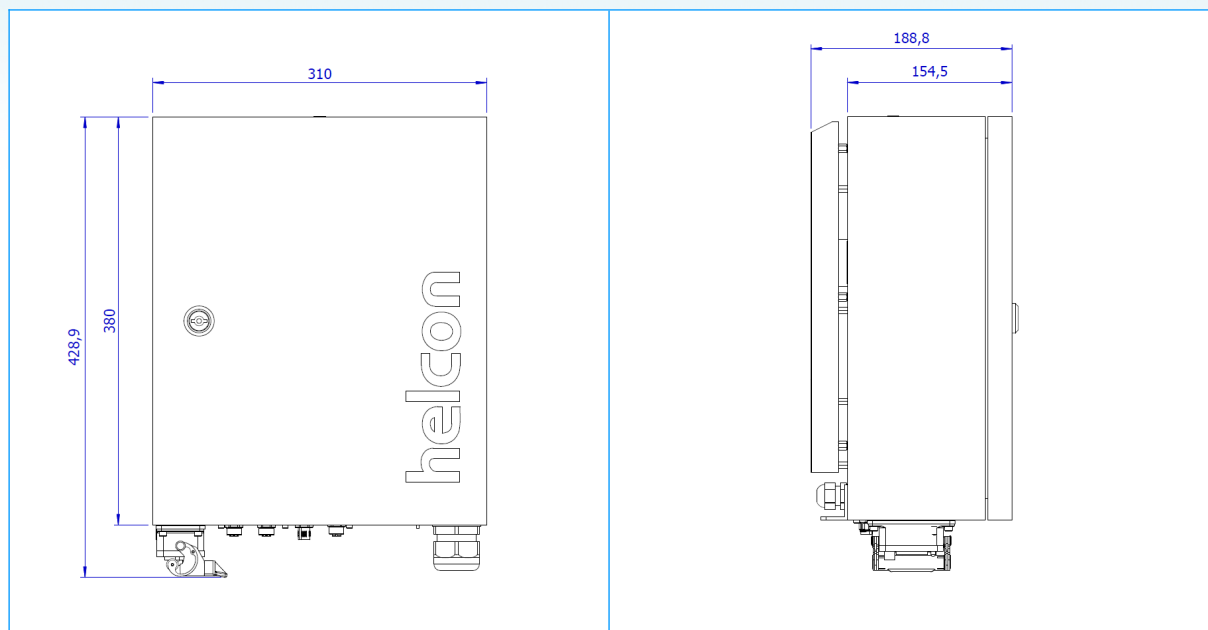

Data here mentioned are subject to changes without any notice.